

MODEL LT-35

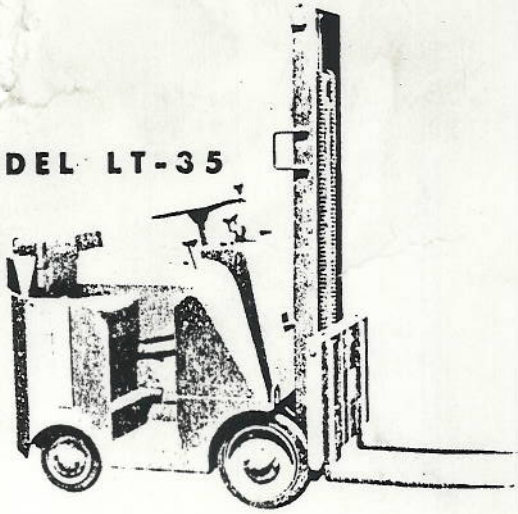

MODEL LT-40

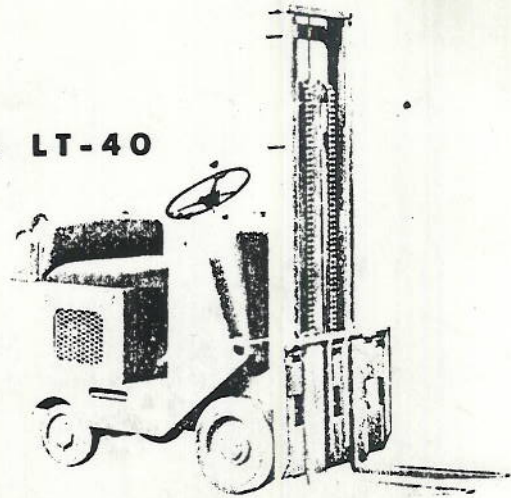

| MODEL | LT-35 | LT-40 | LT-44 | LT-48 |
|-------------------------|--|--------------------------|--------------------------|--------------------------|
| Cap., lbs. — inch lbs. | (A) 1,500 — 38,500 (B) 2,000 — 51,500 | 3,000 - 79,500 | 4,000 — 106,000 | 4,000 — 142,000 |
| Load Center | 15" | 15" | 15" | 24" |
| Lift Height | 72" 84" 108" 120" | 72" 84" 108" 120" 132" | 72" 84" 108" 120" 132" | 72" 84" 108" 120" 132" |
| Mast Height Lowered | 64" 70" 82" 82" | 65" 71" 83" 83" 95" | 65" 71" 83" 83" 95" | 65" 71" 83" 83" 95" |
| Mast Height Extended | 96" 108" 132" 144" | 97" 109" 133" 145" 157" | 97" 109" 133" 145" 157" | 97" 109" 133" 145" 157" |
| Free Lift | 24" 24" 24" 12" | 24" 24" 24" 12" 24" | 24" 24" 24" 12" 24" | 24" 24" 24" 12" 24" |
| Weight, lbs. | (A) 3000 3020 3060 3070 (B) 3390 3410 3450 3460 | 4380-4420-4490-4510-4560 | 5050-5090-5170-5200-5260 | 5780-5820-5900-5920-5980 |
| Tilt | 3°-5° Fwd., 10° Bkwd. | 3°-5° Fwd., 10° Bkwd. | 3°-5° Fwd., 10° Bkwd. | 3°-5° Fwd., 10° Bkwd. |
| Length, Less Forks | 59" | 70" | 74" | 78½" |
| Width, Overall | 35" | 37" | 37" | 37" |
| Wheelbase | 35" | 40" | 44" | 48" |
| Underclearance | 5" | 6½" | 6½" | 6½" |
| Carriage Rollers, No. | 4 | 4 | 4 | 4 |
| Carriage Width | 35" | 35" | 35" | 35" |
| Ht., Carr. Above Forks | 23" | 24" | 24" | 24" |
| Turning Radius, Out. | 58" | 68" | 72" | 76" |
| Turning Radius, In. | 6" | 6½" | 8" | 9" |
| Turns in Inter. Aisles | 54" | 62" | 66" | 69" |
| Speed of Travel | up to 7 mph | up to 7 mph | up to 7 mph | up to 7 mph |
| Speed of Lift, Loaded | 35 F.P.M. | 37 F.P.M. | 37 F.P.M. | 37 F.P.M. |
| Forks, Standard Length | 30" | 30" | 36" | 36" |
| Lateral Adj., In.-In. | 5½" | 6½" | 6½" | 6½" |
| Lateral Adj., Out.-Out. | 33½" | 33" | 33" | 33" |
| Tread, Steer — Drive | 27¼" — 29½" | 28¼" — 29¼" | 28½" — 30¼" | 28½" — 30¼" |
| Tires, Steer | 12" x 3½" x 8" | 12" x 4" x 8" | 12" x 4½" x 8" | 12" x 4½" x 8" |
| Tires, Drive | 16" x 3½" x 12½" | 17" x 5" x 12½" | 17" x 6" x 12½" | 17" x 6" x 12½" |
| Engine, Continental | N-62 | Y-112 | Y-112 | Y-112 |

MODEL LT-44

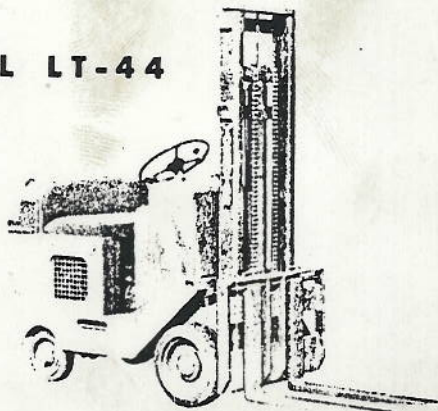

MODEL LT-48

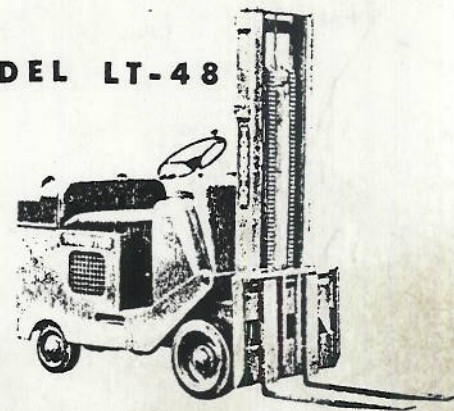

MODEL LT-50

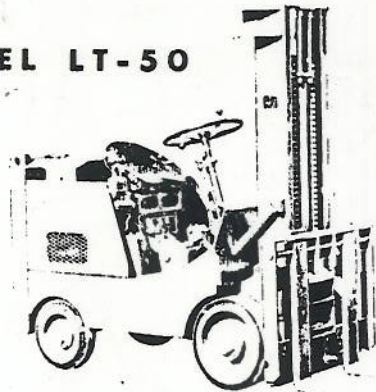

MODEL LT-56

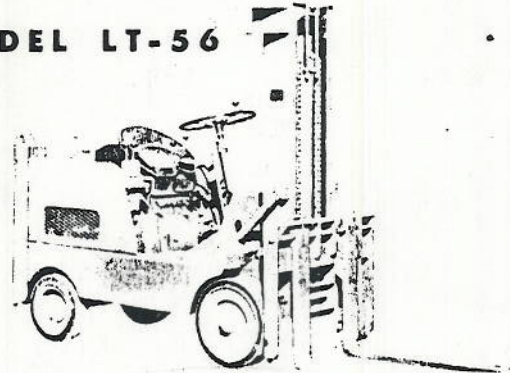

| MODEL | LT-50 | LT-56 | LT-60 |
|-------------------------|--------------------------|--------------------------|--|
| Cap., lbs. inch lbs. | 5,000 -- 175,000 | 6,000 -- 240,000 | (A) 4,000 -- 183,000 (B) 5,000 -- 229,000 (C) 6,000 -- 275,000 |
| Load Center | 20" | 25" | 25" |
| Lift Height | 72" 84" 108" 114" 144" | 72" 84" 108" 114" 144" | 72" 84" 108" |
| Mast Height Lowered | 65" 71" 83" 83" 104" | 65" 71" 83" 83" 104" | 69" 75" 87" |
| Mast Height Extended | 105" 117" 141" 147" 177" | 105" 117" 141" 147" 177" | 110" 122" 146" |
| Free Lift | 15" 15" 15" 9" 21" | 15" 15" 15" 9" 21" | 12" 12" 12" |
| Weight, lbs. | 7530-7590-7720-7740-7980 | 8415-8480-8610-8635-9000 | (A) 7405 7470 7600 (B) 8025 8090 8220 (C) 8965 9030 9160 |
| Tilt | 3° S Fwd., 10° Bkwd. | 3° S Fwd., 10° Bkwd. | 3° S Fwd., 10° Bkwd. |
| Length, Less Forks | 88" | 94" | 106" |
| Width, Overall | 42" | 42" | 55" |
| Wheelbase | 50" | 56" | 60" |
| Underclearance | 6" | 7" | 10½" |
| Carriage Rollers, No. | 4 | 4 | 4 |
| Carriage Width | 42" | 42" | 42" |
| Ht., Carr. Above Forks | 32" | 32" | 37" |
| Turning Radius, Out. | 81" | 89" | A & B 125"; C 131" |
| Turning Radius, In. | 21" | 26" | A & B 50"; C 58" |
| Turns in Inter. Aisles | 66" | 71" | 90" |
| Speed of Travel | up to 8 mph | up to 8 mph | up to 11 mph |
| Speed of Lift, Loaded | 40 F.P.M. | 40 F.P.M. | 45 F.P.M. |
| Forks, Standard Length | 36" | 42" | 42" |
| Lateral Adj., In.-In. | 8" | 8" | 8" |
| Lateral Adj., Out.-Out. | 39" | 39" | 39" |
| Tread, Steer Drive | 33½" -- 30½" | 34½" -- 30½" | 35" -- 45" |
| Tires, Steer | 17" x 5" x 12½" | 17" x 6" x 12½" | A & B 6.50 x 10" C 7.50 x 10" |
| Tires, Drive | 20" x 6" x 16" | 20" x 4" x 16" dual | 8.25 x 15" |
| Engine, Continental | F-162 | F-162 | F-209 |

MODEL LT-60

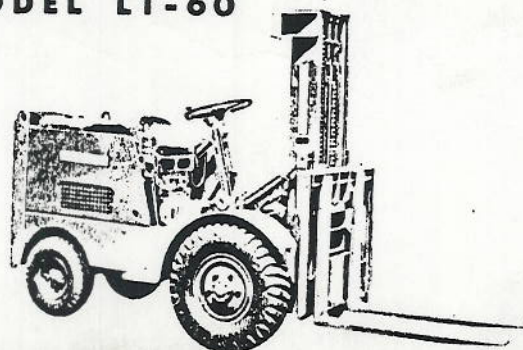

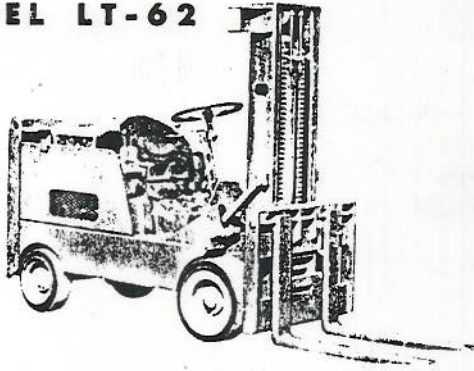
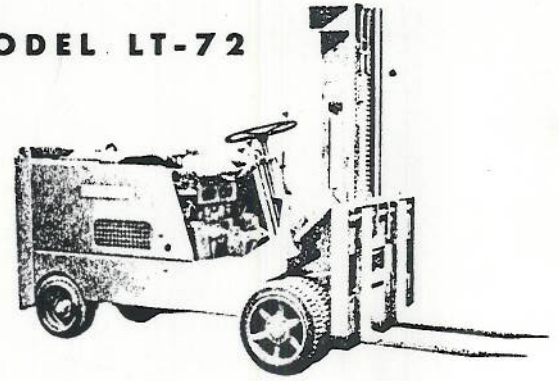
MODEL LT-62**MODEL LT-72**

| MODEL | LT-62 | LT-72 | LT-90 |
|-------------------------|--|---|---|
| Cap., lbs. — inch lbs. | 7,000 — 287,000 | 10,000 — 410,000 | 15,000 — 675,000 |
| Load Center | 25" | 25" | 25" |
| Lift Height | 72" 84" 104" 144" | 74" 104" | 74" 104" |
| Mast Height Lowered | 67" 73" 83" 106" | 71" 86" | 80 ¹ / ₂ " 95 ¹ / ₂ " |
| Mast Height Extended | 105" 117" 137" 177" | 107" 137" | 117 ¹ / ₂ " 147 ¹ / ₂ " |
| Free Lift | 15" 15" 15" 21" | 18" 18" | 20 ¹ / ₂ " 20 ¹ / ₂ " |
| Weight, lbs. | 9420 9490 9610 9900 | 12080 12350 | 16,300 16,700 |
| Tilt | 3°-5° Fwd., 10° Bkwd. | 3°-5° Fwd., 10° Bkwd. | 3° Fwd., 10° Bkwd. |
| Length, Less Forks | 101" | 112" | 134 ¹ / ₂ " |
| Width, Overall | 42" | 53" | 58 ¹ / ₂ " |
| Wheelbase | 62" | 72" | 90" |
| Underclearance | 7" | 7" | 8" |
| Carriage Rollers, No. | 8 | 8 | 8 |
| Carriage Width | 42" | 42" | 57" |
| Ht., Carr. Above Forks | 31" | 31" | 41 ¹ / ₂ " |
| Turning Radius, Out. | 97" | 117" | 145" |
| Turning Radius, In. | 27" | 27" | 47" |
| Turns in Inter. Aisles | 78" | 99" | 112" |
| Speed of Travel | up to 8 mph | up to 8 mph | up to 5 ¹ / ₂ mph |
| Speed of Lift, Loaded | 40 F.P.M. | 34 F.P.M. | 26 F.P.M. |
| Forks, Standard Length | 42" | 42" | 42" |
| Lateral Adj., In.-In. | 8" | 8" | 14" |
| Lateral Adj., Out.-Out. | 39" | 39" | 54" |
| Tread, Steer—Drive | 34 ⁵ / ₈ "—32 ¹ / ₁₆ " | 34 ⁵ / ₈ "—40" | 35 ⁵ / ₈ "—41 ¹ / ₂ " |
| Tires, Steer | 17" x 7" x 12 ¹ / ₈ " | 17" x 7" x 12 ¹ / ₈ " | 18" x 8" x 12 ¹ / ₈ " |
| Tires, Drive | 20" x 5" x 16" dual | 20" x 6" x 16" dual | 22" x 8" x 16" dual |
| Engine, Continental | F-209 | F-209 | F-226 |

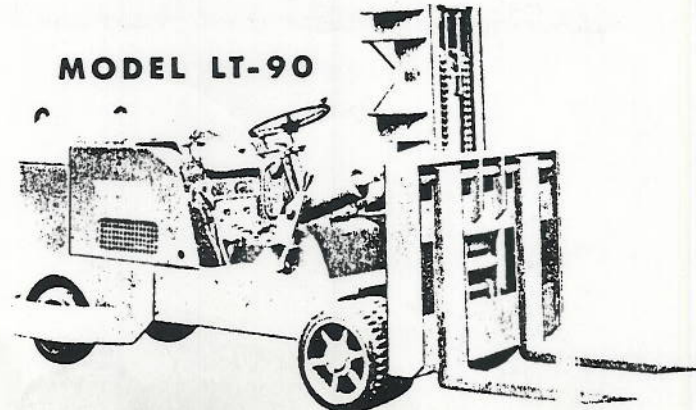
MODEL LT-90

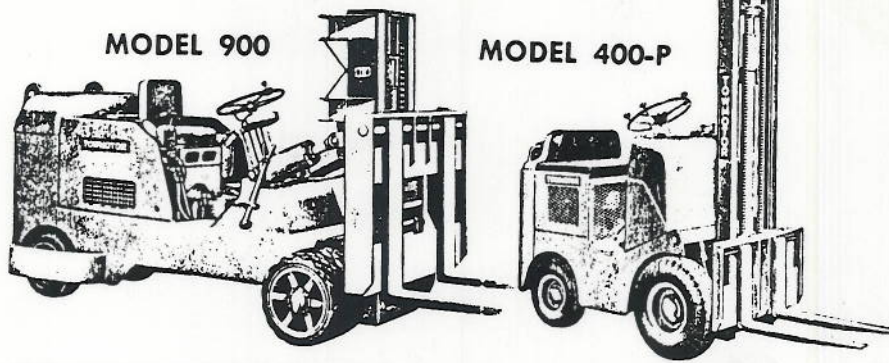

| MODEL | 900 900-LP | 400-P 400-PLP |
|--|--|--|
| Capacity, lbs.—inch lbs. | (A) 15,000—660,000 (B) 18,000—796,500 | 2,000—79,000 |
| Load Center | 24" | 24" |
| Lift Height | 74" 104" | 72" 108" 120" |
| Maximum Fork Height | 76 1/4" 106 1/4" | 73 1/2" 109 1/2" 121 1/2" |
| Mast Height Lowered | 80" 95" | 65" 83" 83" |
| Mast Height Extended | 118" 148" | 92" 128" 140" |
| Free Lift | 22" 22" | 21 1/2" 21 1/2" 9 1/2" |
| *Weight, lbs. | Gasoline: (A) 16,300 16,700 (B) 18,000 18,400 LP-Gas: (A) 16,350 16,750 (B) 18,050 18,450 | Gasoline: 4510 4630 4650 LP-Gas: 4550 4670 4690 |
| Tilt | 3° Fwd., 10° Bkwd. | 3° Fwd., 12° Bkwd. |
| Length, Less Forks | 134" | 74" |
| Width, Overall | 58 1/2" | 34 1/4" |
| Wheelbase | 90" | 40" |
| Underclearance | 8" | 7 1/8" |
| Carriage Rollers, No. | 8 | 4 |
| Carriage Width | 57" | 34" |
| Carriage Ht. Above Floor | 44" | 20" |
| Turning Radius, Outside | 145" | 72" |
| Turning Radius, Inside | 43" | 12 1/2" |
| Turns in Intersecting Aisles | 104" | 60 1/2" |
| Min. Aisle Right Angle Stacking | (A) 207" (B) 207 1/4" | 117 1/2" |
| Speed of Travel | up to 5 1/2 mph | up to 9 mph |
| Speed of Lift, Loaded | 27 F.P.M. | 37 F.P.M. |
| Forks, Standard Length | 42" | 30" |
| Lateral Adj., In-In | 10 1/2" | 6 1/2" |
| Lateral Adj., Out-Out | 54" | 32" |
| Tread, Steer—Drive | 34 1/4"—(A) 41 1/2", (B) 40 1/2" | 27 1/2"—27 1/2" |
| Tires, Steer | 18" x 8" x 12 1/2" Cushion | 5.00" x 8" Pneumatic |
| Tires, Drive | (A) 22" x 8" x 16" Dual (B) 22" x 9" x 16" Cushion | 6.50" x 10" Pneumatic |
| Drive Axle to Fork Face | (A) 20" (B) 20 1/4" | 15 1/2" |
| Seat Height Above Floor | 49 1/2" | 41 3/4" |
| Ht. of Truck Exclusive of Mast | 62 1/4" (LP-Gas, 65") | 59 1/4" (LP-Gas, 61 1/2") |
| Gasoline & LPG Engine—Continental Diesel Engine—Continental | F-226 | Y-112 |

MODEL 390

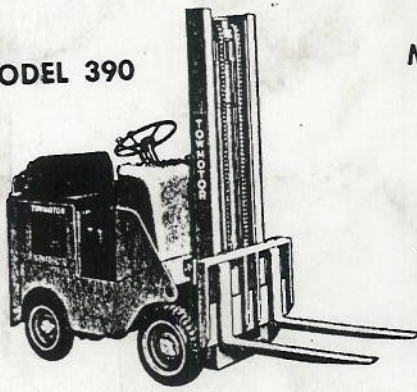

MODEL 420

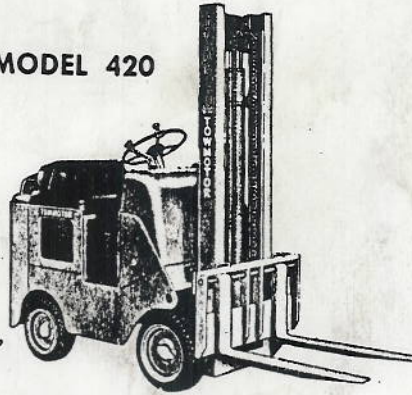

MODEL 460

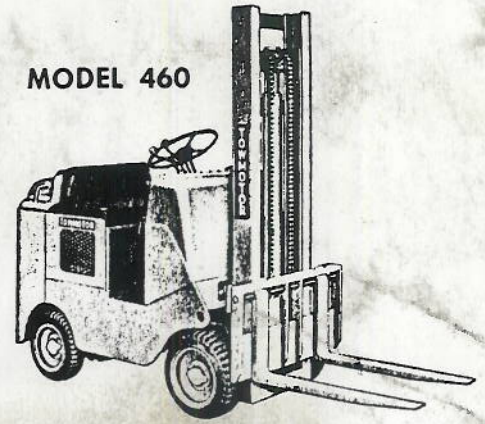

| MODEL | 390 390-LP | | | | 420 420-LP | | | | 460 460-LP 460-D | | | |
|---------------------------------|--|------|------|------|--|------|------|------|--|------|------|------|
| Cap., lbs.—inch lbs. | 3,000—82,500 | | | | 4,000—110,000 | | | | 4,000—146,000 | | | |
| Load Center | 15" | | | | 15" | | | | 24" | | | |
| Lift Height | 72" | 108" | 120" | 144" | 72" | 108" | 120" | 144" | 72" | 108" | 120" | 144" |
| Max. Fork Height | 74" | 110" | 122" | 146" | 74" | 110" | 122" | 146" | 74" | 110" | 122" | 146" |
| **Mast Height Lowered | 65" | 83" | 83" | 101" | 65" | 83" | 83" | 101" | 65" | 83" | 83" | 101" |
| ***Mast Height Extended | 92" | 128" | 140" | 164" | 92" | 128" | 140" | 164" | 92" | 128" | 140" | 164" |
| Free Lift | 25½" | 25½" | 13½" | 25½" | 25½" | 25½" | 13½" | 25½" | 25½" | 25½" | 13½" | 25½" |
| *Weight, lbs. | Gasoline: 4835-4975-5000-5125 LP-Gas: 4875-5015-5040-5165 | | | | Gasoline: 5550-5690-5715-5840 LP-Gas: 5600-5740-5765-5890 | | | | Gasoline: 6210-6350-6375-6500 LP-Gas: 6260-6400-6425-6550 Diesel: 6425-6565-6590-6715 | | | |
| Tilt | 3°-5° Fwd., 10° Bkwd. | | | | 3°-5° Fwd., 10° Bkwd. | | | | 3°-5° Fwd., 10° Bkwd. | | | |
| Length, Less Forks | 71¼" | | | | 74¼" | | | | 78¼" | | | |
| Width, Overall | 37¾" | | | | 38¼" | | | | 38¼" | | | |
| Wheelbase | 39" | | | | 42" | | | | 46" | | | |
| Underclearance | 8¾" | | | | 7" | | | | 7¼" | | | |
| Carriage Rollers, No. | 4 | | | | 4 | | | | 4 | | | |
| Carriage Width | 37" | | | | 37" | | | | 37" | | | |
| Ht., Carr. Above Floor | 20" | | | | 20" | | | | 20" | | | |
| Turning Radius, Out | 68" | | | | 71" | | | | 75" | | | |
| Turning Radius, In | 5" | | | | 5½" | | | | 6" | | | |
| Turns in Inter. Aisles | 61" | | | | 63½" | | | | 65" | | | |
| Min. Aisle Right Angle Stacking | 110½" | | | | 119½" | | | | 123½" | | | |
| Speed of Travel | up to 8 mph | | | | up to 8 mph | | | | up to 8 mph | | | |
| Speed of Lift, Loaded | 37 F.P.M. | | | | 37 F.P.M. | | | | 37 F.P.M. | | | |
| Forks, Standard Length | 30" | | | | 36" | | | | 36" | | | |
| Lateral Adj., In-In. | 6½" | | | | 6½" | | | | 6½" | | | |
| Lateral Adj., Out-Out | 35" | | | | 35" | | | | 35" | | | |
| Tread, Steer—Drive | 32¾"—31¾" | | | | 31¾"—31¾" | | | | 31¾"—31¾" | | | |
| Tires, Steer | 16¼" x 4" x 11¼" Cushion | | | | 16¼" x 5" x 11¼" Cushion | | | | 16¼" x 5" x 11¼" Cushion | | | |
| Tires, Drive | 17¾" x 6" x 12½" Cushion | | | | 18" x 7" x 12½" Cushion | | | | 18" x 7" x 12½" Cushion | | | |
| Drive Axle to Fork Face | 12½" | | | | 12½" | | | | 12½" | | | |
| Seat Height Above Floor | 42" | | | | 42" | | | | 42" | | | |
| Ht. of Truck Excl. of Mast | 58¼" (LP Gas, 61½") | | | | 58¼" (LP-Gas, 61½") | | | | 58¼" (LP-Gas, 61½") | | | |
| Engine, Continental | Y-112 | | | | F-140 | | | | F-140 (Diesel: GD-157) | | | |

MODEL 500

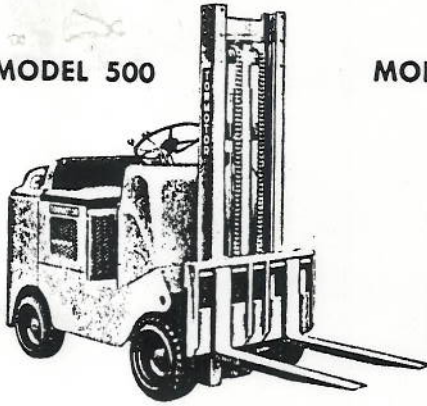

**MODEL L500-P
500-P**

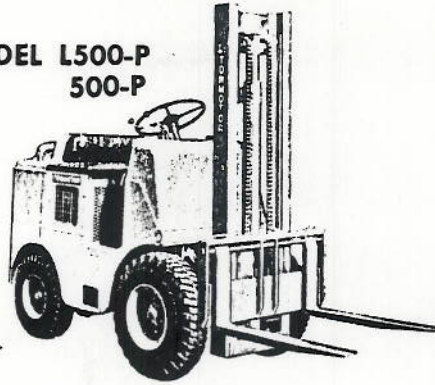

MODEL 680-P

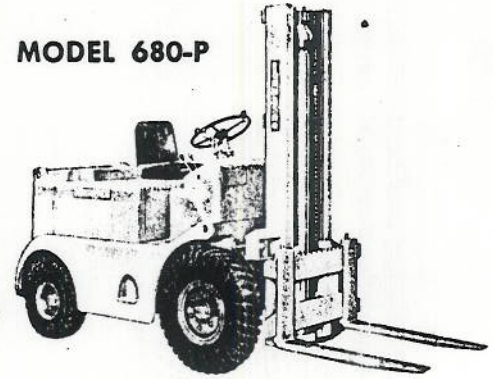

| MODEL | 500 500-LP 500-D | L500-P L500-PLP L500-PD | 500-P 500-PLP 500-PD | 680-P 680-PLP 680-PD |
|---------------------------------|--|--|--|---|
| Cap., lbs.—inch lbs. | 5,000—183,750 | 3,000—128,250 | 4,000—171,000 | (A) 6,000—271,500 (B) 7,000—318,500 |
| Load Center | 24" | 24" | 24" | 24" |
| Lift Height | 72" 108" 120" 144" | 72" 108" 120" | 72" 108" 120" | 84" 120" 144" |
| Max. Fork Height | 74½" 110¼" 122¼" 146¼" | 73½" 109½" 121½" | 73¾" 109¾" 121¾" | 86" 122" 146" |
| **Mast Height Lowered | 55" 83" 83" 101" | 67" 85" 85" | 67" 85" 85" | 68" 86" 98" |
| ***Mast Height Extended | 92" 128" 140" 164" | 92¼" 128¼" 140¼" | 92¼" 128¼" 140¼" | 111" 147" 171" |
| Free Lift | 25¾" 25¾" 13¾" 25¾" | 25½" 25½" 13½" | 25¾" 25¾" 13¾" | 17" 17" 17" |
| *Weight, lbs. | Gasoline: 7235-7375-7400-7525 LP-Gas: 7280-7420-7445-7570 Diesel: 7450-7590-7615-7740 | 6145 Gasoline: 6285 LP-Gas: 6195 Diesel: 6360 6500 6525 | 6785 Gasoline: 6925 LP-Gas: 6835 Diesel: 7000 7140 7165 | (A) 9365 Gasoline: 9650 LP-Gas: (B) 10275 Diesel: 10560 9840 10750 |
| Tilt | 3°-5° Fwd., 10° Bkwd. | 3°-5° Fwd., 10° Bkwd. | 3°-5° Fwd., 10° Bkwd. | 3°-5° Fwd., 10° Bkwd. |
| Length, Less Forks | 82½" | 85" | 88½" | 109¼" |
| Width, Overall | 40¼" | 41½" | 41½" | A-53½"—B-72" |
| Wheelbase | 50" | 50" | 50" | 68" |
| Clearance | 7¼" | 9½" (Diesel 8") | 9½" (Diesel 8") | 10¾" |
| Carriage Rollers, No. | 4 | 4 | 4 | 4 |
| Carriage Width | 37" | 41" | 41" | 43" |
| Ht., Carr. Above Floor | 20" | 20¼" | 20¼" | A-27"—B-26½" |
| Turning Radius, Out | 81" | 85½" | 87" | 110" |
| Turning Radius, In | 10¼" | 18" | 18" | A-20"—B-11" |
| Turns in Inter. Aisles | 69" | 70½" | 73½" | A-89¼"—B-96¼" |
| Min. Aisle Right Angle Stacking | 129¼" | 140¼" | 141¾" | A-173¼"—B-173½" |
| Speed of Travel | up to 8 mph | up to 10 mph | up to 10 mph | up to 11.5 mph |
| Speed of Lift, Loaded | 37 F.P.M. | 37 F.P.M. | 37 F.P.M. | 55 F.P.M. |
| Forks, Standard Length | 36" | 36" | 36" | 42" |
| Lateral Adj., In-In. | 6½" | 6½" | 6½" | 0" |
| Lateral Adj., Out-Out | 35" | 39" | 39" | 43" |
| Tread, Steer—Drive | 32¼"—32¼" | 32¼"—34" | 32¼"—34" | A-42½"—45" B-42½"—54½" |
| Tires, Steer | 16¼" x 6" x 11¼" Cushion | 6.50" x 10" Pneumatic | 6.50" x 10" Pneumatic | 7.50" x 10" Pneumatic |
| Tires, Drive | 18" x 8" x 12¼" Cushion | 7.00" x 12" Pneumatic | 7.00" x 12" Pneumatic | (A) 8.25" x 15"—Pneumatic (B) 7.50" x 15"—Dual Pneumatic |
| Drive Axle to Fork Face | 12¼" | 18¾" | 18¾" | A-21¼"—B-21½" |
| Seat Height Above Floor | 42" | 46" | 45" | 51½" |
| Ht. of Truck Excl. of Mast | 58¼" (LP-Gas, 61½") | 62¼" (LP Gas, 64") | 62¼" (LP-Gas, 63½") | 69" |
| Engine, Continental | F-140 (Diesel: GD-157) | F-140 (Diesel: GD-157) | F-140 (Diesel: GD-157) | F-209 (Diesel: HD-260) |

MODEL 350

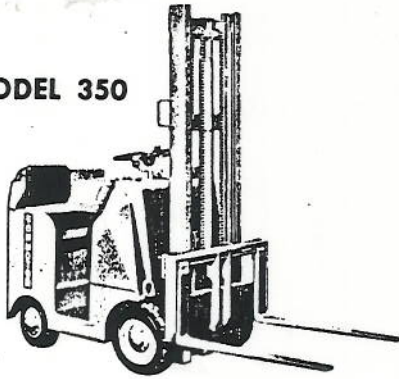

MODEL 391



MODEL 440
410

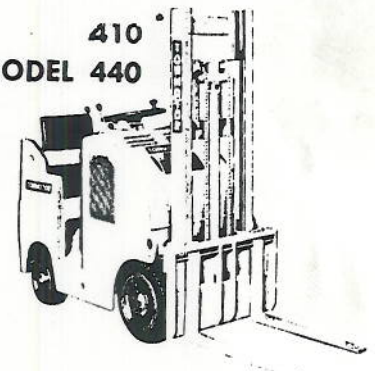

Unless otherwise noted, individual model specifications are the same for all applicable power types.

| MODEL | 350 350-LP | 391 391-LP | 410 410-LP | 440 440-LP |
|---|--|--|--|--|
| Capacity, lbs.—inch lbs. | (A) 1,500—39,750 (B) 2,000—53,000 (C) 2,000—71,000 | 3,000—82,500 | 2,000—72,750 | 3,000—113,250 |
| Load Center | (A&B) 15" (C) 24" | 15" | 24" | 24" |
| Lift Height | 72" 84" 108" 120" | 72" 108" 120" 144" | 72" 108" 120" 144" | 72" 108" 120" 144" |
| Maximum Fork Height | 74" 86" 110" 122" | 74" 110" 122" 146" | 74" 110" 122" 146" | 74" 110" 122" 146" |
| Mast Height Lowered | 65" 71" 83" 83" | 65" 83" 83" 101" | 65" 83" 83" 101" | 65" 83" 83" 101" |
| Mast Height Extended | 92 1/4" 104 1/4" 128 1/4" 140 1/4" | 92" 128" 140" 164" | 92 1/8" 128 1/8" 140 1/8" 164 1/8" | 92 1/8" 128 1/8" 140 1/8" 164 1/8" |
| Free Lift | 25 1/2" 25 1/2" 25 1/2" 13 1/2" | 25 1/2" 25 1/2" 13 1/2" 25 1/2" | 25 1/2" 25 1/2" 13 1/2" 25 1/2" | 25 1/2" 25 1/2" 13 1/2" 25 1/2" |
| *Weight, lbs. | Gasoline: (A) 3095 3120 3170 3180 (B) 3405 3430 3580 3640 (C) 4130 4150 4190 4200 | Gasoline: 4835 4975 5000 5125 LP-Gas: 4875 5015 5040 5165 | Gasoline: 4615 4675 4685 4745 LP-Gas: 4655 4715 4725 4785 | Gasoline: 5810 5950 6075 6200 LP-Gas: 5855 5995 6120 6245 |
| Tilt | 3°-5° Fwd., 10° Bkwd. | 3°-5° Fwd., 10° Bkwd. | 3°-5° Fwd., 10° Bkwd. | 3°-5° Fwd., 10° Bkwd. |
| Length, Less Forks | (A&B) 60 1/4" (C) 61 3/4" | 71 1/4" | 70 3/8" | 74 1/4" |
| Width, Overall | 35" | 37 3/4" | 32" | 35 1/4" |
| Wheelbase | 35" | 39" | 41" | 44" |
| Underclearance | 5" | 8 3/8" | 4 1/2" | 4 1/2" |
| Carriage Rollers, No. | 4 | 4 | 4 | 4 |
| Carriage Width | 35" | 37" | 32" | 32" |
| Carriage Ht. Above Floor | 20 1/4" | 20" | 20 3/8" | 20 3/8" |
| Turning Radius, Outside | (A&B) 58" (C) 60 1/2" | 68" | 61 3/4" | 65 1/4" |
| Turning Radius, Inside | 5" | 5" | 1 7/8" | 1 3/4" |
| Turns in Intersecting Aisles | (A&B) 55" (C) 56" | 61" | 56" | 60 1/4" |
| Min. Aisle Right Angle Stacking | (A&B) 99 1/2" (C) 102" | 110 1/2" | 104 1/8" | 115" |
| Speed of Travel | up to 8 mph | up to 8 mph | up to 9 pmh | up to 9 mph |
| Speed of Lift, Loaded | 40 F.P.M. | 48 F.P.M. | 85 F.P.M. | 75 F.P.M. |
| Forks, Standard Length | 30" | 30" | 30" | 36" |
| Lateral Adj., In-In. | 5 1/2" | 6 1/2" | 5 1/2" | 6 1/2" |
| Lateral Adj., Out-Out | 33" | 35" | 29 3/8" | 29 7/8" |
| Tread, Steer—Drive | 28 3/16"—28 5/16" | 32 3/4"—31 1/4" | 27"—27" | 27"—29 1/4" |
| Tires, Steer | 13" x 3 1/2" x 8" Cushion | 16 1/4" x 4" x 11 1/4" Cushion | 13" x 3 1/2" x 8" Cushion | 13" x 4 1/2" x 8" Cushion |
| Tires, Drive | 17" x 4 1/2" x 12 1/8" Cushion | 17 3/4" x 6" x 12 1/8" Cushion | 17 3/4" x 5" x 12 1/8" Cushion | 17 3/4" x 6" x 12 1/8" Cushion |
| Drive Axle to Fork Face | 11 1/2" | 12 1/2" | 12 3/4" | 13 3/4" |
| Seat Height Above Floor | 32 3/4" | 42" | 32" | 32" |
| Ht. of Truck Exclusive of Mast | 50 1/4" | 60" (LP Gas, 61 3/8") | 48" | 48" |
| Gasoline & LPG Engine—Continental Diesel Engine—Continental | N-62 | Y-112 | Y-112 | Y-112 |

MODEL 421



MODEL L461

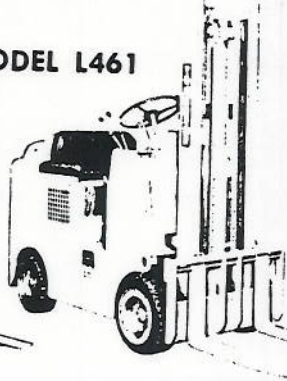

MODEL 461

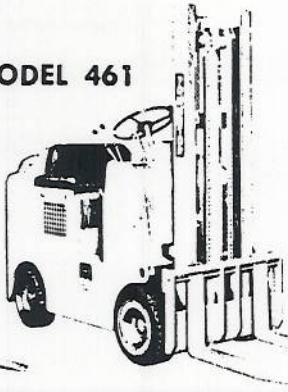

MODEL 501

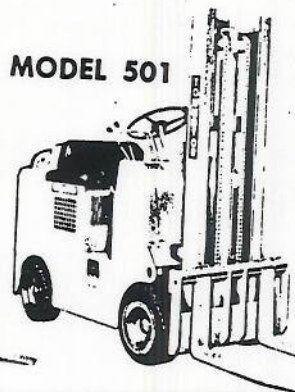

| MODEL | 421 421-LP | L461 L461-LP L461-D | 461 461-LP 461-D | 501 501-LP 501-D |
|-----------------------------------|--|--|--|--|
| Capacity, lbs.—inch lbs. | 4,000—110,000 | 3,000—109,500 | 4,000—146,000 | 5,000—183,750 |
| Load Center | 15" | 24" | 24" | 24" |
| Lift Height | 72" 108" 120" 144" | 72" 108" 120" 144" | 72" 108" 120" 144" | 72" 108" 120" 144" |
| Maximum Fork Height | 74" 110" 122" 146" | 74" 110" 122" 146" | 74" 110" 122" 146" | 74½" 110½" 122½" 146½" |
| Mast Height Lowered | 65" 83" 83" 101" | 65" 83" 83" 101" | 65" 83" 83" 101" | 65" 83" 83" 101" |
| Mast Height Extended | 92" 128" 140" 164" | 92" 128" 140" 164" | 92" 128" 140" 164" | 92" 128" 140" 164" |
| Free Lift | 25½" 35½" 13½" 25½" | 25½" 25½" 13½" 25½" | 25½" 25½" 13½" 25½" | 25¾" 25¾" 13¾" 25¾" |
| *Weight, lbs. | Gasoline: 5550 5690 5715 5840 LP-Gas: 5600 5740 5765 5890 | Gasoline: 5285 5425 5450 5575 LP-Gas: 5335 5475 5500 5625 Diesel: 5500 5640 5665 5790 | Gasoline: 6210 6350 6375 6500 LP-Gas: 6260 6400 6425 6550 Diesel: 6425 6565 6590 6715 | Gasoline: 7235 7375 7400 7525 LP-Gas: 7280 7420 7445 7570 Diesel: 7450 7590 7615 7740 |
| Tilt | 3°-5° Fwd., 10° Bkwd. | 3°-5° Fwd., 10° Bkwd. | 3°-5° Fwd., 10° Bkwd. | 3°-5° Fwd., 10° Bkwd. |
| Length, Less Forks | 74¼" | 78¼" | 78¼" | 82¼" |
| Width, Overall | 38¼" | 38¼" | 38¼" | 40¼" |
| base | 42" | 46" | 46" | 50" |
| Underclearance | 7¼" | 7¼" | 7¼" | 7¼" |
| Carriage Rollers, No. | 4 | 4 | 4 | 4 |
| Carriage Width | 37" | 37" | 37" | 37" |
| Carriage Ht. Above Floor | 20" | 20" | 20" | 20" |
| Turning Radius, Outside | 71" | 75" | 75" | 81" |
| Turning Radius, Inside | 5½" | 6" | 6" | 10¼" |
| Turns in Intersecting Aisles | 63½" | 65" | 65" | 69" |
| Min. Aisle Right Angle Stacking | 119½" | 123½" | 123½" | 129¾" |
| Speed of Travel | up to 8 mph | up to 8 mph | up to 8 mph | up to 8 mph |
| Speed of Lift, Loaded | 50 F.P.M. | 50 F.P.M. | 50 F.P.M. | 48 F.P.M. |
| Forks, Standard Length | 36" | 36" | 36" | 36" |
| Lateral Adj., In-In | 6½" | 6½" | 6½" | 6½" |
| Lateral Adj., Out-Out | 35" | 35" | 35" | 35" |
| Tread, Steer—Drive | 31¾" — 31¼" | 31¾" — 31¼" | 31¾" — 31¼" | 32¾" — 32¼" |
| Tires, Steer | 16¼" x 5" x 11¼" Cushion | 16¼" x 5" x 11¼" Cushion | 16¼" x 5" x 11¼" Cushion | 16¼" x 6" x 11¼" Cushion |
| Tires, Drive | 18" x 7" x 12¼" Cushion | 18" x 7" x 12¼" Cushion | 18" x 7" x 12¼" Cushion | 18" x 8" x 12¼" Cushion |
| Drive Axle to Fork Face | 12½" | 12½" | 12½" | 12¾" |
| Seat Height Above Floor | 43¾" | 43¾" | 43¾" | 43¾" |
| Ht. of Truck Exclusive of Mast | 60" (LP-Gas, 61¾") | 60" (LP-Gas, 61¾") | 60" (LP-Gas, 61¾") | 60" (LP-Gas, 61¾") |
| Gasoline & LPG Engine—Continental | F-140 | F-140 | F-140 | F-140 |
| Diesel Engine—Continental | | GD-157 | GD-157 | GD-157 |

MODEL 540



MODEL 600

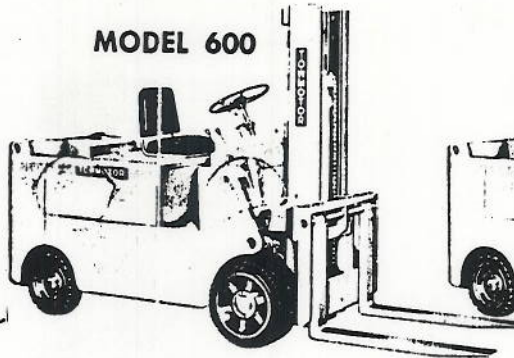

MODEL 670

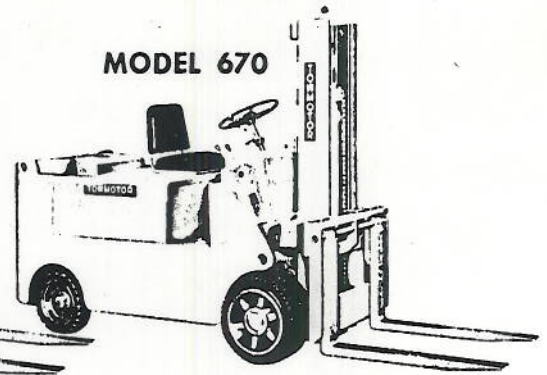

| MODEL | 540 540-LP 540-D | | | 600 600-LP 600-D | | | 670 670-LP 670-D | | |
|--|---|-----------------------------------|-----------------------------------|---|-----------------------------------|-----------------------------------|--|-----------------------------------|-----------------------------------|
| Capacity, lbs.—inch lbs. | (A) 6,000—236,250 (B) 7,000—275,625 | | | (A) 8,000—315,000 (B) 9,000—356,625 | | | (A) 10,000—396,250 (B) 11,000—435,875 | | |
| Load Center | 24" | | | 24" | | | 24" | | |
| Lift Height | 84" | 120" | 144" | 84" | 108" | 144" | 74" | 98" | 144" |
| Maximum Fork Height | 85 ³ / ₄ " | 121 ³ / ₄ " | 145 ³ / ₄ " | 86" | 110" | 146" | 76" | 100 ¹ / ₂ " | 146 ¹ / ₂ " |
| Mast Height Lowered | 65" | 83" | 95" | 71" | 83" | 101" | 71" | 83" | 106" |
| Mast Height Extended | 108 ⁵ / ₈ " | 144 ⁵ / ₈ " | 168 ⁵ / ₈ " | 116 ¹ / ₈ " | 140 ¹ / ₈ " | 176 ¹ / ₈ " | 105 ³ / ₄ " | 129 ³ / ₄ " | 175 ³ / ₄ " |
| Free Lift | 16 ³ / ₄ " | 16 ³ / ₄ " | 16 ³ / ₄ " | 26 ¹ / ₄ " | 26 ¹ / ₄ " | 26 ¹ / ₄ " | 36 ¹ / ₄ " | 36 ¹ / ₄ " | 36 ¹ / ₄ " |
| *Weight, lbs. | Gasoline: (A) 9095 9380 9570 (B) 9945 10230 10420 | | | Gasoline: (A) 11000 11190 11475 (B) 11740 11930 12215 | | | Gasoline: (A) 12240 12430 12795 (B) 13140 13330 13695 | | |
| Tilt | 3°-5° Fwd., 10° Bkwd. | | | 3°-5° Fwd., 10° Bkwd. | | | 3°-5° Fwd., 10° Bkwd. | | |
| Length, Less Forks | (A) 91 ¹ / ₈ " (B) 93 ³ / ₈ " | | | (A) 99 ³ / ₈ " (B) 100 ³ / ₈ " | | | 107 ³ / ₈ " | | |
| Width, Overall | 44" | | | (A) 44 ¹ / ₂ " (B) 46" | | | 52 ³ / ₄ " | | |
| Wheelbase | 54" | | | 60" | | | 67" | | |
| Underclearance | 6 ³ / ₄ " | | | 6 ³ / ₄ " | | | 6 ³ / ₄ " | | |
| Carriage Rollers, No. | 4 | | | 4 | | | 4 | | |
| Carriage Width | 44" | | | 44" | | | 44" | | |
| Carriage Ht. Above Floor | 24 ⁵ / ₈ " | | | 32 ¹ / ₈ " | | | 31 ³ / ₄ " | | |
| Turning Radius, Outside | (A) 85" (B) 87" | | | (A) 93 ¹ / ₂ " (B) 94 ¹ / ₂ " | | | 102" | | |
| Turning Radius, Inside | 4" | | | (A) 6 ³ / ₄ " (B) 5 ³ / ₄ " | | | 5 ³ / ₄ " | | |
| Turns in Intersecting Aisles | (A) 74 ¹ / ₂ " (B) 75 ¹ / ₄ " | | | (A) 79" (B) 79 ¹ / ₂ " | | | 85 ¹ / ₂ " | | |
| Min. Aisle Right Angle Stacking | (A) 142 ³ / ₈ " (B) 144 ³ / ₈ " | | | (A) 150 ³ / ₈ " (B) 152 ¹ / ₈ " | | | 159 ⁵ / ₈ " | | |
| Speed of Travel | up to 9 mph | | | up to 9 mph | | | up to 8 mph | | |
| Speed of Lift, Loaded | (A) 50 F.P.M. (B) 45 F.P.M. | | | 50 F.P.M. | | | 45 F.P.M. | | |
| Forks, Standard Length | 42" | | | 42" | | | 42" | | |
| Lateral Adj., In-In | 3 ¹ / ₄ " | | | 1 ¹ / ₄ " | | | 1 ¹ / ₄ " | | |
| Lateral Adj., Out-Out | 41 ⁷ / ₈ " | | | 41 ³ / ₈ " | | | 41 ³ / ₈ " | | |
| Tread, Steer—Drive | 37 ¹ / ₄ "—36" | | | 37 ¹ / ₂ "—34" | | | 37 ¹ / ₂ "—(A) 40", (B) 38 ³ / ₄ " | | |
| Tires, Steer | 17 ³ / ₄ " x 6" x 12 ¹ / ₈ " Cushion | | | 18" x 7" x 12 ¹ / ₈ " Cushion | | | 18" x 7" x 12 ¹ / ₈ " Cushion | | |
| Tires, Drive | 22" x 8" x 16" Cushion | | | (A) 22" x 5" x 16" Dual (B) 22" x 6" x 16" Cushion | | | (A) 22" x 6" x 16" Dual (B) 22" x 7" x 16" Cush. | | |
| Drive Axle to Fork Face | 15 ³ / ₈ " | | | (A) 15 ¹ / ₈ " (B) 15 ³ / ₈ " | | | 15 ³ / ₈ " | | |
| Seat Height Above Floor | 47" | | | 47" | | | 47" | | |
| Ht. of Truck Exclusive of Mast | 63 ⁵ / ₈ " | | | 63 ⁵ / ₈ " | | | 63 ⁵ / ₈ " | | |
| Gasoline & LPG Engine—Continental Diesel Engine—Continental | F-209 HD-260 | | | F-209 HD-260 | | | F-209 HD-260 | | |

*MODEL 351S

Model 350S

Model 411S

Model 441S

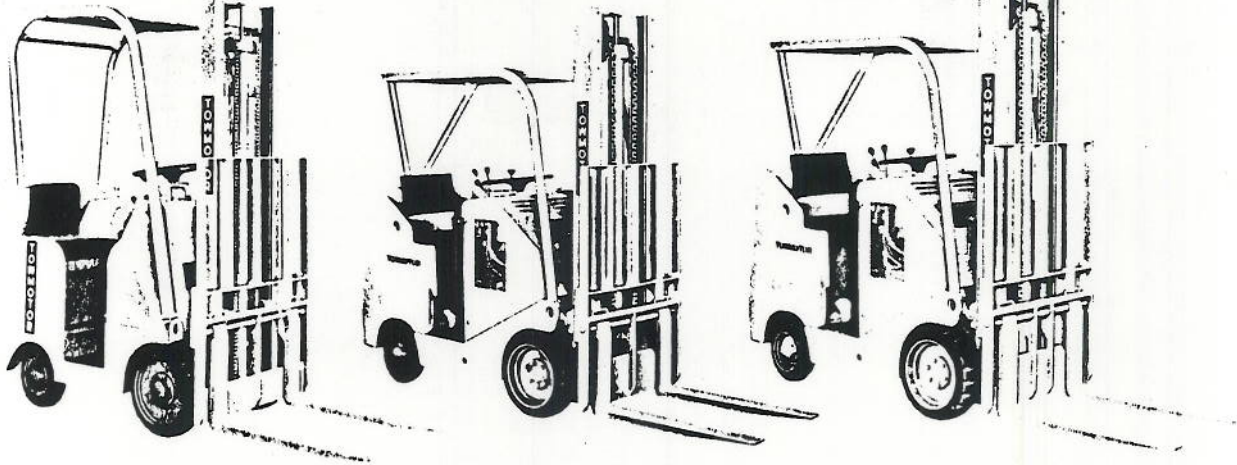

| MODEL | 350SG2015 | 350SG2024 | 411SG2024 | 411SG3015 | 441SG3024 | 441SG4015 |
|---|--|--|--|--|-------------------------------|-------------------------------|
| Capacity, lbs. | 2000 | 2000 | 2000 | 3000 | 3000 | 4000 |
| Load Center | 15" | 24" | 24" | 15" | 24" | 15" |
| Inch-Pound Rating | 53,250 | 71,250 | 73,250 | 82,875 | 113,250 | 115,000 |
| Centerline of Drive Axle to Fork Face | 11 $\frac{1}{8}$ " | 11 $\frac{1}{8}$ " | 12 $\frac{3}{8}$ " | 12 $\frac{3}{8}$ " | 13 $\frac{3}{4}$ " | 13 $\frac{3}{4}$ " |
| Maximum Lift Height with Rated Load ① | 144" | 144" | 144" | 144" | 144" | 144" |
| Maximum Fork Height | 146" | 146" | 146" | 146" | 146" | 146" |
| Mast Lowered Height | 90" | 90" | 90" | 90" | 90" | 90" |
| Mast Extended Height { Less Load Backrest With Load Backrest | 164 $\frac{3}{8}$ " 194" | 164 $\frac{3}{8}$ " 194" | 164 $\frac{3}{8}$ " 193 $\frac{3}{8}$ " | 164 $\frac{3}{8}$ " 193 $\frac{3}{8}$ " | 164 $\frac{1}{4}$ " 194" | 164 $\frac{1}{4}$ " 194" |
| Free Lift | 18" | 18" | 18" | 18" | 17 $\frac{1}{2}$ " | 17 $\frac{1}{2}$ " |
| Truck Weight, lbs. | 4070 | 4435 | 4850 | 5230 | 6255 | 6440 |
| Tilt—Degrees { Forward Backward | 5 10 | 5 10 | 5 10 | 5 10 | 5 10 | 5 10 |
| Speed of Lift, Loaded | 45 fpm | 45 fpm | 95 fpm | 95 fpm | 75 fpm | 75 fpm |
| Speed of Travel | Up to 8.0 mph | Up to 8.0 mph | Up to 9.0 mph | Up to 9.0 mph | Up to 9.0 mph | Up to 9.0 mph |
| Carriage Width | 35" | 35" | 32" | 32" | 32" | 32" |
| Carriage Height { Less Load Backrest With Load Backrest | 20 $\frac{3}{8}$ " 50" | 20 $\frac{3}{8}$ " 50" | 20 $\frac{3}{8}$ " 49 $\frac{3}{8}$ " | 20 $\frac{3}{8}$ " 49 $\frac{3}{8}$ " | 20 $\frac{1}{4}$ " 50" | 20 $\frac{1}{4}$ " 50" |
| Forks, Standard Section and Length | 1 $\frac{1}{2}$ " x 4" x 30" | 1 $\frac{1}{2}$ " x 4" x 30" | 1 $\frac{1}{2}$ " x 4" x 30" | 1 $\frac{1}{2}$ " x 4" x 30" | 1 $\frac{1}{2}$ " x 4" x 36" | 1 $\frac{1}{2}$ " x 4" x 36" |
| Lateral Adjustment, In to In | 1 $\frac{1}{4}$ " | 1 $\frac{1}{4}$ " | 1 $\frac{1}{4}$ " | 1 $\frac{1}{4}$ " | 6 $\frac{1}{2}$ " | 6 $\frac{1}{2}$ " |
| Lateral Adjustment, Out to Out | 33 $\frac{3}{8}$ " | 33 $\frac{3}{8}$ " | 30 $\frac{3}{8}$ " | 30 $\frac{3}{8}$ " | 29 $\frac{7}{8}$ " | 29 $\frac{7}{8}$ " |
| Turning Radius { Outside Inside | 59" 4" | 59" 4" | 61 $\frac{3}{4}$ " 1 $\frac{7}{8}$ " | 63" 1" | 67" 1 $\frac{3}{4}$ " | 67" 1 $\frac{3}{4}$ " |
| Minimum Intersecting Aisle | 54 $\frac{1}{2}$ " | 54 $\frac{1}{2}$ " | 56" | 58" | 61 $\frac{1}{4}$ " | 61 $\frac{1}{4}$ " |
| Minimum Aisle for Right Angle Stacking Less Load Length | 70 $\frac{1}{2}$ " | 70 $\frac{1}{2}$ " | 74 $\frac{3}{8}$ " | 75 $\frac{3}{8}$ " | 80 $\frac{3}{4}$ " | 80 $\frac{3}{4}$ " |
| Overall Width | 35 $\frac{5}{8}$ " | 35 $\frac{5}{8}$ " | 32" | 32" | 35 $\frac{1}{4}$ " | 35 $\frac{1}{4}$ " |
| Wheelbase | 35" | 35" | 41" | 41" | 44" | 44" |
| Overall Length, Less Forks and Towing Eye | 61 $\frac{3}{4}$ " | 61 $\frac{3}{4}$ " | 70 $\frac{1}{4}$ " | 72" | 76 $\frac{1}{4}$ " | 76 $\frac{1}{4}$ " |
| Driver's Overhead Guard Height | 83" | 83" | 71 $\frac{1}{2}$ " | 71 $\frac{1}{2}$ " | 71 $\frac{1}{2}$ " | 71 $\frac{1}{2}$ " |
| Effective Seat Height | 32 $\frac{1}{8}$ " | 32 $\frac{1}{8}$ " | 32" | 32" | 32" | 32" |
| Tread, Steer—Drive | 28 $\frac{3}{16}$ "-29 $\frac{3}{8}$ " | 28 $\frac{3}{16}$ "-29 $\frac{3}{8}$ " | 27"-27" | 27"-27" | 27"-29 $\frac{1}{4}$ " | 27"-29 $\frac{1}{4}$ " |
| Tire Size, Steer | 13" x 3 $\frac{1}{2}$ " x 8" | 13" x 3 $\frac{1}{2}$ " x 8" | 13" x 3 $\frac{1}{2}$ " x 8" | 13" x 4 $\frac{1}{2}$ " x 8" | 13" x 4 $\frac{1}{2}$ " x 8" | 13" x 4 $\frac{1}{2}$ " x 8" |
| Tire Size, Drive | 17" x 4 $\frac{1}{2}$ " x 12 $\frac{1}{8}$ " | 17" x 4 $\frac{1}{2}$ " x 12 $\frac{1}{8}$ " | 17 $\frac{3}{4}$ " x 5" x 12 $\frac{1}{8}$ " | 17 $\frac{3}{4}$ " x 5" x 12 $\frac{1}{8}$ " | 18" x 6" x 12 $\frac{1}{8}$ " | 18" x 6" x 12 $\frac{1}{8}$ " |
| Underclearance, Center of Truck | 5 $\frac{1}{4}$ " | 5 $\frac{1}{4}$ " | 4 $\frac{3}{8}$ " | 4 $\frac{3}{8}$ " | 4 $\frac{3}{8}$ " | 4 $\frac{3}{8}$ " |
| Engine, Continental Model | N-62 | N-62 | Y-112 | Y-112 | Y-112 | Y-112 |
| Optional Power Types Available | LP-Gas | LP-Gas | LP-Gas | LP-Gas | LP-Gas | LP-Gas |

* Engine: Waukesha, ICK

Model 392S



Model 422S

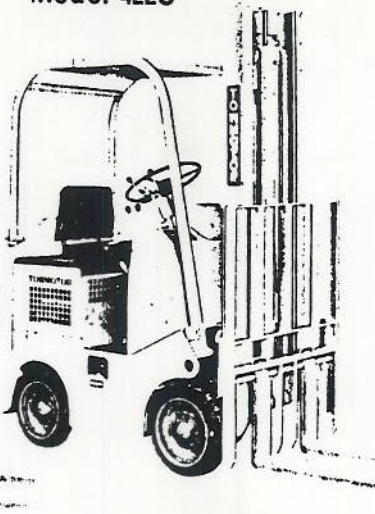

Model 462S
Model 502S

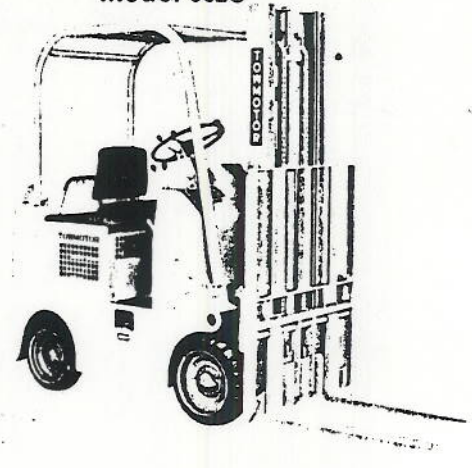

| MODEL | 392SG2024 | 392SG2524 | 422SG3024 | 422SG4015 | 462SG4024 | 502SG5024 |
|---|--|--|--|--|--|--|
| Capacity, lbs. | 2000 | 2500 | 3000 | 4000 | 4000 | 5000 |
| Load Center | 24" | 24" | 24" | 15" | 24" | 24" |
| Inch-Pound Rating | 71,750 | 91,250 | 110,000 | 110,000 | 146,000 | 183,750 |
| Centerline of Drive Axle to Fork Face | 11 $\frac{1}{8}$ " | 12 $\frac{1}{2}$ " | 12 $\frac{1}{2}$ " | 12 $\frac{1}{2}$ " | 12 $\frac{1}{2}$ " | 12 $\frac{3}{4}$ " |
| Maximum Lift Height with Rated Load ① | 144" | 144" | 144" | 144" | 144" | 144" |
| Maximum Fork Height | 146" | 146" | 146" | 146" | 146" | 146 $\frac{1}{4}$ " |
| Mast Lowered Height | 90" | 90" | 90" | 90" | 90" | 90" |
| Mast Extended Height { Less Load Backrest With Load Backrest | 164 $\frac{3}{8}$ " 194" | 164 $\frac{1}{4}$ " 194" | 164 $\frac{1}{4}$ " 194" | 164 $\frac{1}{4}$ " 194" | 164 $\frac{1}{4}$ " 194" | 164 $\frac{1}{4}$ " 194" |
| Free Lift | 18" | 17 $\frac{1}{2}$ " | 17 $\frac{1}{2}$ " | 17 $\frac{1}{2}$ " | 17 $\frac{1}{2}$ " | 17 $\frac{3}{4}$ " |
| Truck Weight, lbs. | 4455 | 5425 | 5825 | 5825 | 6665 | 7680 |
| Tilt—Degrees { Forward Backward | 5 10 | 5 10 | 5 10 | 5 10 | 5 10 | 5 10 |
| Speed of Lift, Loaded | 110 fpm | 80 fpm | 90 fpm | 90 fpm | 80 fpm | 80 fpm |
| Speed of Travel | Up to 8.0 mph | Up to 8.0 mph | Up to 8.0 mph | Up to 8.0 mph | Up to 8.0 mph | Up to 8.0 mph |
| Carriage Width | 35" | 37" | 37" | 37" | 37" | 37" |
| Carriage Height { Less Load Backrest With Load Backrest | 20 $\frac{3}{8}$ " 50" | 20 $\frac{1}{4}$ " 50" | 20 $\frac{1}{4}$ " 50" | 20 $\frac{1}{4}$ " 50" | 20 $\frac{1}{4}$ " 50" | 20 $\frac{1}{4}$ " 50" |
| Forks, Standard Section and Length | 1 $\frac{1}{2}$ " x 4" x 30" | 1 $\frac{1}{2}$ " x 4" x 30" | 1 $\frac{1}{2}$ " x 4" x 36" | 1 $\frac{1}{2}$ " x 4" x 36" | 1 $\frac{1}{2}$ " x 4" x 36" | 1 $\frac{3}{4}$ " x 4" x 36" |
| Lateral Adjustment, In to In | 1 $\frac{1}{4}$ " | 6 $\frac{1}{2}$ " | 6 $\frac{1}{2}$ " | 6 $\frac{1}{2}$ " | 6 $\frac{1}{2}$ " | 6 $\frac{1}{2}$ " |
| Lateral Adjustment, Out to Out | 33 $\frac{3}{8}$ " | 34 $\frac{7}{8}$ " | 34 $\frac{7}{8}$ " | 34 $\frac{7}{8}$ " | 34 $\frac{7}{8}$ " | 34 $\frac{7}{8}$ " |
| Turning Radius { Outside Inside | 68" 5 $\frac{1}{4}$ " | 68 $\frac{3}{8}$ " 5" | 71" 5 $\frac{1}{2}$ " | 71" 5 $\frac{1}{2}$ " | 75" 6" | 81" 10 $\frac{1}{4}$ " |
| Minimum Intersecting Aisle | 60 $\frac{1}{2}$ " | 61 $\frac{1}{2}$ " | 63 $\frac{1}{2}$ " | 63 $\frac{1}{2}$ " | 65" | 69" |
| Minimum Aisle for Right Angle Stacking Less Load Length | 79 $\frac{7}{8}$ " | 80 $\frac{7}{8}$ " | 83 $\frac{1}{2}$ " | 83 $\frac{1}{2}$ " | 87 $\frac{1}{2}$ " | 93 $\frac{3}{4}$ " |
| Overall Width | 37 $\frac{1}{2}$ " | 37 $\frac{3}{4}$ " | 38 $\frac{1}{4}$ " | 38 $\frac{1}{4}$ " | 38 $\frac{1}{4}$ " | 40 $\frac{1}{4}$ " |
| Wheelbase | 39" | 39" | 42" | 42" | 46" | 50" |
| Overall Length, Less Forks and Towing Eye | 70 $\frac{3}{4}$ " | 72 $\frac{3}{8}$ " | 74 $\frac{1}{4}$ " | 74 $\frac{1}{4}$ " | 78 $\frac{1}{4}$ " | 82 $\frac{1}{4}$ " |
| Driver's Overhead Guard Height | 81 $\frac{1}{4}$ " | 81 $\frac{1}{4}$ " | 81 $\frac{1}{4}$ " | 81 $\frac{1}{4}$ " | 81 $\frac{1}{4}$ " | 81 $\frac{1}{4}$ " |
| Effective Seat Height | 40 $\frac{1}{4}$ " | 40 $\frac{1}{4}$ " | 40 $\frac{1}{4}$ " | 40 $\frac{1}{4}$ " | 40 $\frac{1}{4}$ " | 40 $\frac{1}{4}$ " |
| Tread, Steer—Drive | 32 $\frac{1}{8}$ "-32 $\frac{1}{4}$ " | 32 $\frac{1}{8}$ "-31 $\frac{3}{4}$ " | 31 $\frac{3}{4}$ "-31 $\frac{1}{4}$ " | 31 $\frac{3}{4}$ "-31 $\frac{1}{4}$ " | 31 $\frac{3}{4}$ "-31 $\frac{1}{4}$ " | 32 $\frac{3}{4}$ "-32 $\frac{1}{4}$ " |
| Tire Size, Steer | 16 $\frac{1}{4}$ " x 4" x 11 $\frac{1}{4}$ " | 16 $\frac{1}{4}$ " x 4" x 11 $\frac{1}{4}$ " | 16 $\frac{1}{4}$ " x 5" x 11 $\frac{1}{4}$ " | 16 $\frac{1}{4}$ " x 5" x 11 $\frac{1}{4}$ " | 16 $\frac{1}{4}$ " x 5" x 11 $\frac{1}{4}$ " | 16 $\frac{1}{4}$ " x 6" x 11 $\frac{1}{4}$ " |
| Tire Size, Drive | 17 $\frac{3}{4}$ " x 5" x 12 $\frac{1}{8}$ " | 18" x 6" x 12 $\frac{1}{8}$ " | 18" x 7" x 12 $\frac{1}{8}$ " | 18" x 7" x 12 $\frac{1}{8}$ " | 18" x 7" x 12 $\frac{1}{8}$ " | 18" x 8" x 12 $\frac{1}{8}$ " |
| Underclearance, Center of Truck | 5 $\frac{1}{2}$ " | 5 $\frac{1}{2}$ " | 5 $\frac{1}{2}$ " | 5 $\frac{1}{2}$ " | 5 $\frac{1}{2}$ " | 5 $\frac{1}{2}$ " |
| Engine, Continental Model | Y-112 | Y-112 | F-163 | F-163 | F-163 | F-163 |
| Optional Power Types Available | LP-Gas | LP-Gas | LP-Gas | LP-Gas | LP-Gas Diesel | LP-Gas Diesel |

Model 510P

Model 502P

Model 601P

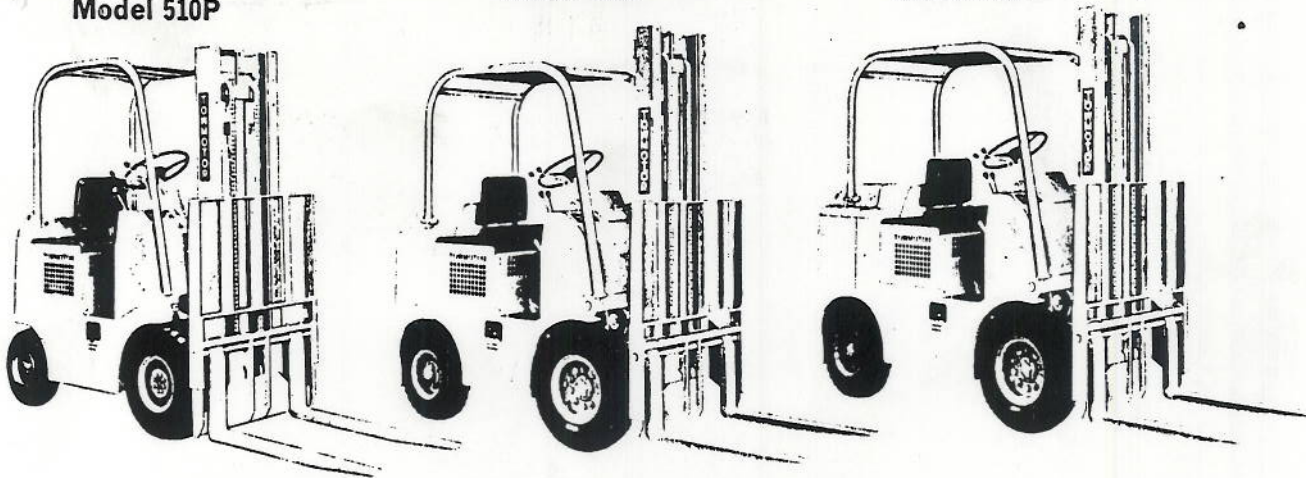

| MODEL | 510PG2024 | 510PG2524 | 502PG3024 | 502PG4024 | 601PG4024 | 601PG5024 |
|---|--|--|---|---|---|---|
| Capacity, lbs. | 2000 | 2500 | 3000 | 4000 | 4000 | 5000 |
| Load Center | 24" | 24" | 24" | 24" | 24" | 24" |
| Inch-Pound Rating | 77,750 | 97,500 | 121,500 | 163,000 | 163,000 | 203,750 |
| Centerline of Drive Axle to Fork Face | 14 ⁷ / ₈ " | 15" | 16 ¹ / ₂ " | 16 ³ / ₄ " | 16 ³ / ₄ " | 16 ³ / ₄ " |
| Maximum Lift Height with Rated Load ① | 144" | 144" | 144" | 144" | 144" | 144" |
| Maximum Fork Height | 146" | 146" | 145 ¹ / ₂ " | 146" | 146" | 146" |
| Mast Lowered Height | 90 ³ / ₄ " | 90 ³ / ₈ " | 92" | 92" | 92" | 92" |
| Mast Extended Height { Less Load Backrest With Load Backrest | 164 ³ / ₈ " 194" | 164 ³ / ₈ " 194" | 164 ¹ / ₄ " 194" | 164 ¹ / ₄ " 194" | 164 ¹ / ₄ " 194" | 164 ¹ / ₄ " 194" |
| Free Lift | 18" | 17 ¹ / ₂ " | 17" | 17 ¹ / ₂ " | 17 ¹ / ₂ " | 17 ¹ / ₂ " |
| Truck Weight, lbs. | 4630 | 5505 | 6330 | 7330 | 7205 | 7885 |
| Tilt—Degrees { Forward Backward | 6 10 | 6 10 | 5 10 | 5 10 | 5 10 | 5 10 |
| Speed of Lift, Loaded | 120 fpm | 90 fpm | 80 fpm | 80 fpm | 80 fpm | 80 fpm |
| Speed of Travel | Up to 11.5 mph | Up to 11.5 mph | Up to 10.0 mph | Up to 10.0 mph | Up to 10.0 mph | Up to 10.0 mph |
| Carriage Width | 35" | 37" | 41" | 41" | 41" | 41" |
| Carriage Height { Less Load Backrest With Load Backrest | 20 ³ / ₈ " 50" | 20 ¹ / ₈ " 50" | 20 ¹ / ₄ " 50" | 20 ¹ / ₄ " 50" | 20 ¹ / ₄ " 50" | 20 ¹ / ₄ " 50" |
| Forks, Standard Section and Length | 1 ¹ / ₂ " x 4" x 30" | 1 ¹ / ₂ " x 4" x 30" | 1 ¹ / ₂ " x 4" x 36" | 1 ³ / ₄ " x 4" x 36" | 1 ³ / ₄ " x 4" x 36" | 1 ³ / ₄ " x 4" x 36" |
| Lateral Adjustment, In to In | 1 ¹ / ₄ " | 6 ¹ / ₂ " | 6 ¹ / ₂ " | 6 ¹ / ₂ " | 6 ¹ / ₂ " | 6 ¹ / ₂ " |
| Lateral Adjustment, Out to Out | 33 ³ / ₈ " | 34 ⁷ / ₈ " | 38 ⁷ / ₈ " | 38 ⁷ / ₈ " | 38 ⁷ / ₈ " | 38 ⁷ / ₈ " |
| Turning Radius { Outside Inside | 68" 2" | 68" 2" | 77 ¹ / ₄ " 3 ¹ / ₂ " | 77 ¹ / ₄ " 1 ¹ / ₂ " ① | 87 ³ / ₄ " 6 ¹ / ₂ " | 88 ¹ / ₄ " ① 0" ② |
| Minimum Intersecting Aisle | 62 ³ / ₄ " | 62 ³ / ₄ " | 70 ¹ / ₂ " | 72 ¹ / ₂ " ① | 77" | 81 ¹ / ₄ " ② |
| Minimum Aisle for Right Angle Stacking Less Load Length | 82 ⁷ / ₈ " | 83" | 94" | 94" | 104 ¹ / ₂ " | 105" ③ |
| Overall Width | 37 ¹ / ₂ " | 37 ¹ / ₂ " | 41 ¹ / ₂ " | 45 ¹ / ₂ " ③ | 45 ¹ / ₂ " | 58 ¹ / ₂ " ③ |
| Wheelbase | 51" | 51" | 50" | 50" | 60" | 60" |
| Overall Length, Less Forks and Towing Eye | 78 ³ / ₄ " | 79" | 85 ¹ / ₂ " | 85 ¹ / ₂ " | 95 ¹ / ₂ " | 95 ¹ / ₂ " |
| Driver's Overhead Guard Height | 83 ¹ / ₂ " | 83 ¹ / ₂ " | 86 ³ / ₈ " | 86 ³ / ₈ " | 86 ³ / ₈ " | 86 ³ / ₈ " |
| Effective Seat Height | 42 ¹ / ₄ " | 42 ¹ / ₄ " | 44 ³ / ₄ " | 44 ³ / ₄ " | 44 ³ / ₄ " | 44 ³ / ₄ " |
| Tread, Steer—Drive | 31"-30" | 31"-30" | 34 ¹ / ₈ "-34 ³ / ₁₆ " | 34 ¹ / ₈ "-38 ³ / ₁₆ " ④ | 34 ¹ / ₈ "-38 ³ / ₁₆ " | 34 ¹ / ₈ "-42 ⁵ / ₈ " ④ |
| Tire Size, Steer | 5.00" x 8" 8 Ply | 5.00" x 8" 8 Ply | 6.50" x 10" 10 Ply | 6.50" x 10" 10 Ply | 6.50" x 10" 10 Ply | 6.50" x 10" 10 Ply |
| Tire Size, Drive | 6.50" x 10" 10 Ply | 6.50" x 10" 10 Ply | 7.00" x 12" 12 Ply | 7.00" x 12" 12 Ply | 7.00" x 12" 12 Ply | 7.00" x 12" 8 Ply Dual ⑤ |
| Underclearance, Center of Truck | 7 ¹ / ₄ " | 7 ¹ / ₄ " | 9 ³ / ₈ " | 9 ³ / ₈ " | 9 ³ / ₈ " | 9 ³ / ₈ " |
| Engine, Continental Model | F-163 | F-163 | F-163 | F-163 | F-163 | F-163 |
| Optional Power Types Available | LP-Gas | LP-Gas | LP-Gas Diesel | LP-Gas Diesel | LP-Gas Diesel | LP-Gas Diesel |

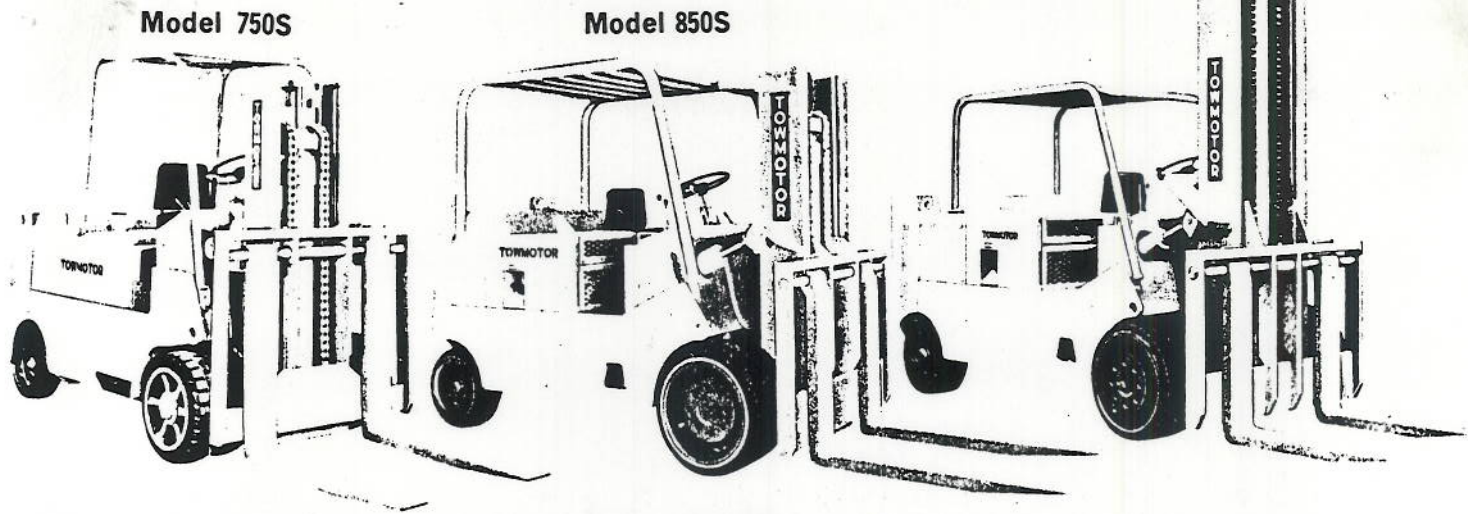

| MODEL | 750SG15024 | 850SG15024 | 850SG18024 | 850SG20024 | 950SG20030 | 950SG22030 | 950SG25030 |
|--|---|--|--|--|------------------------------|-------------------------------|-------------------------------|
| Capacity, lbs. | 15,000 | 15,000 | 18,000 | 20,000 | 20,000 | 22,000 | 25,000 |
| Load Center | 24" | 24" | 24" | 24" | 30" | 30" | 30" |
| Inch-Pound Rating | 628,125 | 693,750 | 841,500 | 935,000 | 1,032,500 | 1,135,750 | 1,290,625 |
| Centerline of Drive Axle to Fork Face | 17 $\frac{7}{8}$ " | 22 $\frac{1}{4}$ " | 22 $\frac{3}{4}$ " | 22 $\frac{3}{4}$ " | 21 $\frac{5}{8}$ " | 21 $\frac{5}{8}$ " | 21 $\frac{5}{8}$ " |
| Maximum Lift Height with Rated Load (1) | 144" | 144" | 144" | 144" | 144" | 144" | 144" |
| Maximum Fork Height | 146 $\frac{1}{4}$ " | 146 $\frac{1}{4}$ " | 146 $\frac{3}{4}$ " | 146 $\frac{3}{4}$ " | 147 $\frac{1}{4}$ " | 147 $\frac{1}{4}$ " | 147 $\frac{1}{4}$ " |
| Mast Lowered Height | 111" | 111" | 111" | 111" | 126" | 126" | 126" |
| Mast Extended Height | 189 $\frac{1}{4}$ " | 192 $\frac{3}{8}$ " | 192 $\frac{3}{8}$ " | 192 $\frac{3}{8}$ " | 200 $\frac{1}{4}$ " | 200 $\frac{1}{4}$ " | 200 $\frac{1}{4}$ " |
| Free Lift | 22 $\frac{1}{2}$ " | 22 $\frac{1}{4}$ " | 22 $\frac{3}{4}$ " | 22 $\frac{3}{4}$ " | None | None | None |
| Truck Weight, lbs. | 19,100 | 21,540 | 23,610 | 25,165 | 26,935 | 28,375 | 30,585 |
| Tilt—Degrees | 5 | 5 | 5 | 5 | 5 | 5 | 5 |
| Forward | 10 | 10 | 10 | 10 | 10 | 10 | 10 |
| Backward | | | | | | | |
| Speed of Lift, Loaded | 35 fpm | 50 fpm | 50 fpm | 50 fpm | 50 fpm | 50 fpm | 50 fpm |
| Speed of Travel | Up to 6.5 mph | Up to 8.5 mph | Up to 8.5 mph | Up to 8.5 mph | Up to 7.5 mph | Up to 7.5 mph | Up to 7.5 mph |
| Carriage Width | 54" | 54" | 54" | 54" | 62" | 62" | 62" |
| Carriage Height | 45 $\frac{1}{4}$ " | 48 $\frac{3}{8}$ " | 48 $\frac{3}{8}$ " | 48 $\frac{3}{8}$ " | 56 $\frac{1}{4}$ " | 56 $\frac{1}{4}$ " | 56 $\frac{1}{4}$ " |
| Forks, Standard Section and Length | 2 $\frac{1}{4}$ " x 7" x 42" | 2 $\frac{1}{4}$ " x 7" x 42" | 2 $\frac{3}{4}$ " x 7" x 42" | 2 $\frac{3}{4}$ " x 7" x 42" | 3 $\frac{1}{4}$ " x 8" x 48" | 3 $\frac{1}{4}$ " x 8" x 48" | 3 $\frac{1}{4}$ " x 8" x 48" |
| Lateral Adjustment, In to In | 17" | 16" | 16" | 16" | 19 $\frac{1}{2}$ " | 19 $\frac{1}{2}$ " | 19 $\frac{1}{2}$ " |
| Lateral Adjustment, Out to Out | 50 $\frac{1}{4}$ " | 50 $\frac{1}{4}$ " | 50 $\frac{1}{4}$ " | 50 $\frac{1}{4}$ " | 57 $\frac{3}{4}$ " | 57 $\frac{3}{4}$ " | 57 $\frac{3}{4}$ " |
| Turning Radius | Outside 110 $\frac{3}{8}$ " Inside 6 $\frac{1}{2}$ " | 112 $\frac{1}{2}$ " 4 $\frac{1}{2}$ " | 112 $\frac{1}{2}$ " 2 $\frac{1}{2}$ " | 112 $\frac{1}{2}$ " 2 $\frac{1}{2}$ " | 128" 4 $\frac{1}{2}$ " | 128" $\frac{1}{2}$ " | 128" $\frac{1}{2}$ " |
| Minimum Intersecting Aisle | 93 $\frac{1}{2}$ " | 96" | 97 $\frac{1}{2}$ " | 97 $\frac{1}{2}$ " | 109 $\frac{1}{4}$ " | 112" | 112" |
| Minimum Aisle for Right Angle Stacking Less Load Length | 128 $\frac{1}{4}$ " | 134 $\frac{1}{4}$ " | 135 $\frac{1}{4}$ " | 135 $\frac{1}{4}$ " | 149 $\frac{3}{8}$ " | 149 $\frac{3}{8}$ " | 149 $\frac{3}{8}$ " |
| Overall Width | 58 $\frac{1}{2}$ " | 54" | 58" | 58" | 62" | 70" | 70" |
| Wheelbase | 75" | 85" | 85" | 85" | 95" | 95" | 95" |
| Overall Length, Less Forks and Towing Eye | 117 $\frac{3}{8}$ " | 127" | 127" | 127" | 141 $\frac{3}{8}$ " | 141 $\frac{3}{8}$ " | 141 $\frac{3}{8}$ " |
| Driver's Overhead Guard Height | 88" | 94 $\frac{3}{4}$ " | 94 $\frac{3}{4}$ " | 94 $\frac{3}{4}$ " | 94 $\frac{3}{4}$ " | 94 $\frac{3}{4}$ " | 94 $\frac{3}{4}$ " |
| Effective Seat Height | 47 $\frac{1}{4}$ " | 50 $\frac{3}{4}$ " | 50 $\frac{3}{4}$ " | 50 $\frac{3}{4}$ " | 50 $\frac{3}{4}$ " | 50 $\frac{3}{4}$ " | 50 $\frac{3}{4}$ " |
| Tread, Steer—Drive | 38"-42 $\frac{1}{2}$ " | 46"-40" | 45"-42" | 44"-42" | 51"-46" | 51"-50" | 51"-50" |
| Tire Size, Steer | 18" x 8" x 12 $\frac{1}{8}$ " | 22" x 7" x 16" | 22" x 8" x 16" | 22" x 9" x 16" | 22" x 10" x 16" Solid | 22" x 10" x 16" Solid | 22" x 10" x 16" Solid |
| Tire Size, Drive | 22" x 8" x 16" Dual | 28" x 7" x 22" Solid Dual | 28" x 16" x 22" Solid | 28" x 16" x 22" Solid | 28" x 16" x 22" Solid | 28" x 10" x 22" Solid Dual | 28" x 10" x 22" Solid Dual |
| Underclearance, Center of Truck | 8" | 6 $\frac{1}{2}$ " | 6 $\frac{1}{2}$ " | 6 $\frac{1}{2}$ " | 8 $\frac{1}{2}$ " | 8 $\frac{1}{2}$ " | 8 $\frac{1}{2}$ " |
| Engine | *F-245 | 1V-266 | 1V-266 | 1V-266 | 1V-304 | 1V-304 | 1V-304 |
| Optional Power Types Available | LP-Gas | LP-Gas Diesel | LP-Gas Diesel | LP-Gas Diesel | LP-Gas | LP-Gas | LP-Gas |

MODEL L501-P

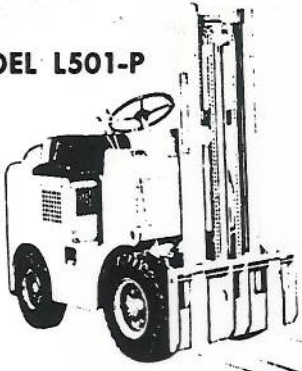

MODEL 501-P

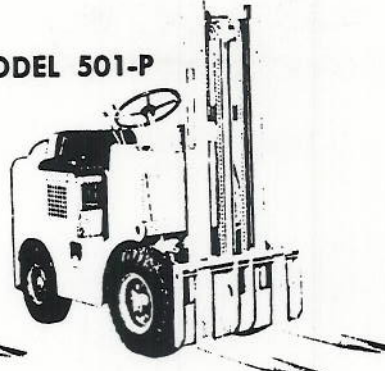

MODEL 680-P

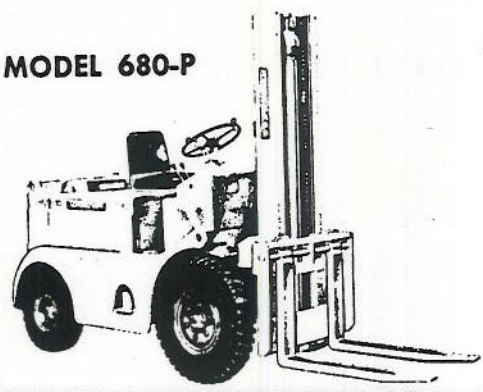

| MODEL | L501-P | L501-PLP | L501-PD | 501-P | 501-PLP | 501-PD | 680-P | 680-PLP | 680-PD | | |
|-----------------------------------|---|----------|----------|---|---------|----------|---|---------------|-----------------------------|----------|----------|
| Capacity, lbs.—inch lbs. | 3,000—127,500 | | | 4,000—171,000 | | | (A)6,000—272,500 (B)7,000—317,625 | 8,000—363,000 | | | |
| Load Center | 24" | | | 24" | | | 24" | | 24" | | |
| Lift Height | 72" | 108" | 120" | 144" | 72" | 108" | 120" | 144" | 84" | 120" | 144" |
| Maximum Fork Height | 73 1/2" | 109 1/2" | 121 1/2" | 145 1/2" | 73 3/4" | 109 3/4" | 121 3/4" | 145 3/4" | 86 1/4" | 122 1/4" | 146 1/4" |
| Mast Height Lowered | 67" | 85" | 85" | 103" | 67" | 85" | 85" | 103" | 68" | 86" | 98" |
| Mast Height Extended | 92 1/4" | 128 1/4" | 140 1/4" | 164 1/4" | 92 1/4" | 128 1/4" | 140 1/4" | 164 1/4" | 109 3/8" | 145 3/8" | 169 3/8" |
| Free Lift | 25 1/2" | 25 1/2" | 13 1/2" | 25 1/2" | 25 3/4" | 25 3/4" | 13 3/4" | 25 3/4" | 17 1/4" | 17 1/4" | 17 1/4" |
| *Weight, lbs. | Gasoline: 6145 6285 6310 6555 LP-Gas: 6195 6335 6360 6605 Diesel: 6360 6500 6525 6770 | | | Gasoline: 6785 6925 6950 7235 LP-Gas: 6835 6975 7000 7285 Diesel: 7000 7140 7165 7450 | | | Gasoline: (A) 9515 9800 9990 (B) 10465 10750 10940 | | Gasoline: 11610 11895 12085 | | |
| Tilt | 3°-5° Fwd., 10° Bkwd. | | | 3°-5° Fwd., 10° Bkwd. | | | 3°-5° Fwd., 10° Bkwd. | | 3°-5° Fwd., 10° Bkwd. | | |
| Length, Less Forks | 84 3/4" | | | 88 7/8" | | | 110 3/8" | | 110 3/8" | | |
| Width, Overall | 41 1/2" | | | 41 1/2" | | | 53 3/4" | | 53 3/8" | | |
| Wheelbase | 50" | | | 50" | | | 68" | | 68" | | |
| Underclearance | 9 7/8" (Diesel: 8") | | | 9 7/8" (Diesel: 8") | | | 10 3/8" | | 10 3/8" | | |
| Carriage Rollers, No. | 4 | | | 4 | | | 4 | | 4 | | |
| Carriage Width | 41" | | | 41" | | | 44" | | 44" | | |
| Carriage Ht. Above Floor | 20 1/4" | | | 20 1/4" | | | 25 3/8" | | 32 3/8" | | |
| Turning Radius, Outside | 85 1/2" | | | 87" | | | 110" | | 110" | | |
| Turning Radius, Inside | 18" | | | 18" | | | 20" | | 20" | | |
| Turns in Intersecting Aisles | 70 1/2" | | | 73 1/2" | | | 89 3/4" | | 89 3/4" | | |
| Min. Aisle Right Angle Stacking | 140" | | | 141 3/4" | | | 173 3/8" | | 173 3/8" | | |
| Speed of Travel | up to 10 mph | | | up to 10 mph | | | up to 11.5 mph | | up to 11.5 mph | | |
| Speed of Lift, Loaded | 50 F.P.M. | | | 50 F.P.M. | | | (A)50 F.P.M. (B)45 F.P.M. | | 50 F.P.M. | | |
| Forks, Standard Length | 36" | | | 36" | | | 42" | | 42" | | |
| Lateral Adj., In-In | 6 1/2" | | | 6 1/2" | | | 3 1/4" | | 1 1/4" | | |
| Lateral Adj., Out-Out | 39" | | | 39" | | | 41 7/8" | | 41 3/8" | | |
| Tread, Steer—Drive | 32 3/4"—34" | | | 32 3/4"—34" | | | 42 1/2"—45" | | 42 1/2"—45" | | |
| Tires, Steer | 6.50" x 10" Pneumatic | | | 6.50" x 10" Pneumatic | | | 7.50" x 10" Pneumatic | | 7.50" x 10" Pneumatic | | |
| Tires, Drive | 7.00" x 12" Pneumatic | | | 7.00" x 12" Pneumatic | | | 8.25" x 15" Pneumatic | | 8.25" x 15" Pneumatic | | |
| Drive Axle to Fork Face | 18 1/2" | | | 18 3/4" | | | 21 3/8" | | 21 3/8" | | |
| Seat Height Above Floor | 46 3/4" | | | 46 3/4" | | | 52 1/4" | | 52 1/4" | | |
| Ht. of Truck Exclusive of Mast | 64 1/2" | | | 64 1/2" | | | 69" | | 69" | | |
| Gasoline & LPG Engine—Continental | F-162 GD-157 | | | F-162 GD-157 | | | F-209 HD-260 | | F-226 HD-260 | | |

Model 860P

Model 760P

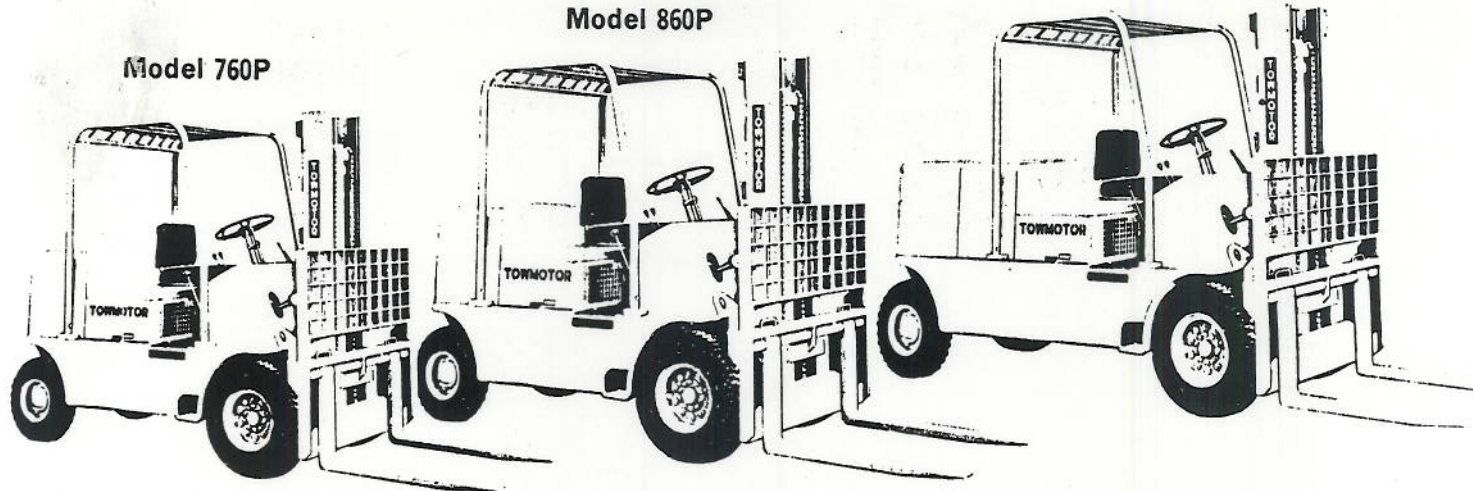

| MODEL | 760PG6024 | 760PG7024 | 860PG8024 | 860PG9024 | 960PG10024 |
|---|--|--|--|--|--|
| Capacity, lbs. | 6000 | 7000 | 8000 | 9000 | 10,000 |
| Load Center | 24" | 24" | 24" | 24" | 24" |
| Inch-Pound Rating | 248,250 | 289,625 | 333,000 | 374,625 | 416,250 |
| Centerline of Drive Axle to Fork Face | 17 $\frac{3}{8}$ " | 17 $\frac{3}{8}$ " | 17 $\frac{3}{8}$ " | 17 $\frac{3}{8}$ " | 17 $\frac{3}{8}$ " |
| Maximum Lift Height with Rated Load ① | 144" | 144" | 144" | 144" | 144" |
| Maximum Fork Height | 146 $\frac{1}{4}$ " | 146 $\frac{1}{4}$ " | 146 $\frac{1}{2}$ " | 146 $\frac{1}{2}$ " | 146 $\frac{1}{2}$ " |
| Mast Lowered Height | 98" | 98" | 104" | 104" | 109" |
| Mast Extended Height { Less Load Backrest With Load Backrest | 169 $\frac{3}{8}$ " 194 $\frac{3}{8}$ " | 169 $\frac{3}{8}$ " 194 $\frac{3}{8}$ " | 176 $\frac{1}{2}$ " 194 $\frac{3}{8}$ " | 176 $\frac{1}{2}$ " 194 $\frac{3}{8}$ " | 178 $\frac{3}{8}$ " 194 $\frac{3}{8}$ " |
| Free Lift | 17 $\frac{1}{4}$ " | 17 $\frac{1}{4}$ " | 26 $\frac{3}{4}$ " | 26 $\frac{3}{4}$ " | 36 $\frac{3}{4}$ " |
| Truck Weight, lbs. | 9535 | 10,405 | 11,125 | 11,795 | 11,800 |
| Tilt—Degrees { Forward Backward | 6 12 | 6 12 | 6 12 | 6 12 | 6 12 |
| Speed of Lift, Loaded | 75 fpm | 75 fpm | 60 fpm | 60 fpm | 55 fpm |
| Speed of Travel | Up to 17.0 mph | Up to 17.0 mph | Up to 17.0 mph | Up to 17.0 mph | Up to 17.0 mph |
| Carriage Width | 54" | 54" | 54" | 54" | 54" |
| Carriage Height { Less Load Backrest With Load Backrest | 25 $\frac{3}{8}$ " 50 $\frac{3}{8}$ " | 25 $\frac{3}{8}$ " 50 $\frac{3}{8}$ " | 32 $\frac{1}{2}$ " 50 $\frac{3}{8}$ " | 32 $\frac{1}{2}$ " 50 $\frac{3}{8}$ " | 34 $\frac{3}{8}$ " 50 $\frac{3}{8}$ " |
| Forks, Standard Section and Length | 1 $\frac{3}{4}$ " x 5" x 42" | 1 $\frac{3}{4}$ " x 5" x 42" | 2" x 5" x 42" | 2" x 5" x 42" | 2" x 6" x 42" |
| Lateral Adjustment, In to In | 1 $\frac{1}{4}$ " | 1 $\frac{1}{4}$ " | 1 $\frac{3}{4}$ " | 1 $\frac{3}{4}$ " | 1 $\frac{3}{4}$ " |
| Lateral Adjustment, Out to Out | 51 $\frac{3}{8}$ " | 51 $\frac{3}{8}$ " | 51 $\frac{3}{8}$ " | 51 $\frac{3}{8}$ " | 51 $\frac{3}{8}$ " |
| Turning Radius { Outside Inside | 99 $\frac{1}{2}$ " 8 $\frac{1}{4}$ " | 99 $\frac{1}{2}$ " 8 $\frac{1}{4}$ " | 110 $\frac{1}{2}$ " 13" | 110 $\frac{1}{2}$ " 13" | 122 $\frac{1}{4}$ " 18" |
| Minimum Intersecting Aisle | 88 $\frac{1}{4}$ " | 88 $\frac{1}{4}$ " | 93 $\frac{1}{4}$ " | 93 $\frac{1}{4}$ " | 96 $\frac{1}{2}$ " |
| Minimum Aisle for Right Angle Stacking Less Load Length | 116 $\frac{7}{8}$ " | 116 $\frac{7}{8}$ " | 128 $\frac{1}{8}$ " | 128 $\frac{1}{8}$ " | 139 $\frac{7}{8}$ " |
| Overall Width | 55" | 55" | 55" | 55" | 55" |
| Wheelbase | 76" | 76" | 86" | 86" | 96" |
| Overall Length, Less Forks and Towing Eye | 109" | 109" | 119" | 119" | 129 $\frac{1}{4}$ " |
| Driver's Overhead Guard Height | 85 $\frac{11}{16}$ " | 86 $\frac{11}{16}$ " | 85 $\frac{11}{16}$ " | 85 $\frac{11}{16}$ " | 85 $\frac{11}{16}$ " |
| Effective Seat Height | 45" | 45" | 45" | 45" | 45" |
| Tread, Steer—Drive | 39 $\frac{3}{16}$ "-38 $\frac{13}{16}$ " | 39 $\frac{3}{16}$ "-38 $\frac{13}{16}$ " | 39 $\frac{3}{16}$ "-38 $\frac{13}{16}$ " | 39 $\frac{3}{16}$ "-38 $\frac{13}{16}$ " | 39 $\frac{3}{16}$ "-38 $\frac{13}{16}$ " |
| Tire Size, Steer | 6.50" x 10" 8 Ply | 6.50" x 10" 10 Ply | 6.50" x 10" 10 Ply | 7.50" x 10" 10 Ply | 7.50" x 10" 10 Ply |
| Tire Size, Drive | 7.00" x 12" 8 Ply Dual | 7.00" x 12" 12 Ply Dual | 7.00" x 12" 12 Ply Dual | 7.00" x 12" 12 Ply Dual | 7.00" x 12" 12 Ply Dual |
| Underclearance, Center of Truck | 8" | 8" | 8" | 8" | 8 $\frac{1}{2}$ " |
| Engine, Continental Model | F-227 | F-227 | F-227 | F-227 | F-227 |
| Optional Power Types Available | LP-Gas | LP-Gas | LP-Gas | LP-Gas | LP-Gas |

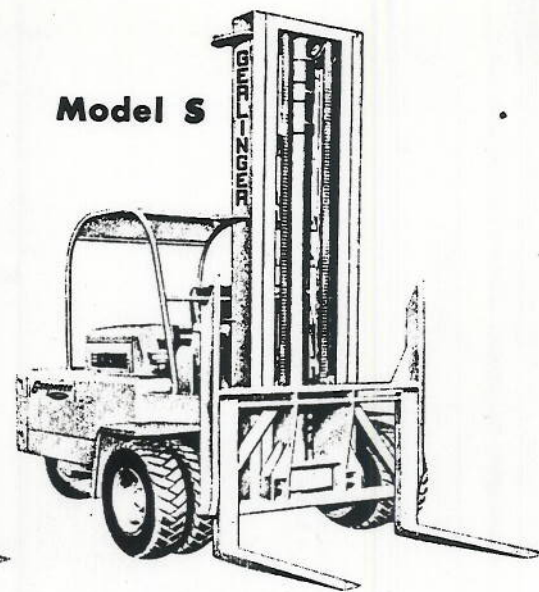
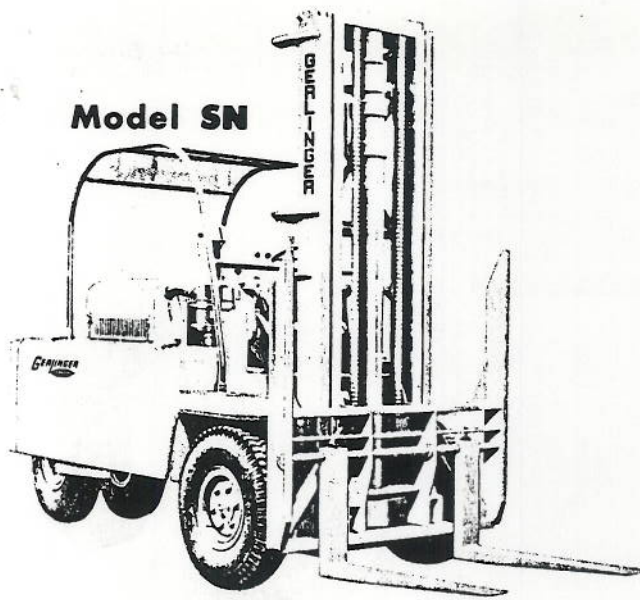

| MODEL | S-10N | S-10 | S-12 | S-15 | S-16 | S-18 |
|--|-----------------|-----------------|-----------------|-----------------|-------------------|-------------------|
| Capacity | 10,000 lbs. | 10,000 lbs. | 12,000 lbs. | 15,000 lbs. | 16,000 lbs. | 18,000 lbs. |
| Load Center | 24" | 24" | 24" | 25" | 25" | 24" |
| Inch-Pound Rating with 135% Safety Factor | 480,000 in-lbs. | 480,000 in-lbs. | 576,000 in-lbs. | 735,000 in-lbs. | 800,000 in-lbs. | 882,000 in-lbs. |
| Inch-Pound Rating BALANCED | 700,000 in-lbs. | 700,000 in-lbs. | 790,000 in-lbs. | 985,000 in-lbs. | 1,080,000 in-lbs. | 1,170,000 in-lbs. |
| Height Mast Lowered | 8' 8" | 8' 7" | 9' 4 1/2" | 9' 4 1/2" | 9' 5 1/2" | 9' 6" |
| Height Mast Extended | 16' 1 1/4" | 16' 1 1/4" | 16' 1 3/4" | 16' 1 3/4" | 16' 1 3/4" | 16' 1 3/4" |
| Height of Lift | 10' 0" | 10' 0" | 10' 0" | 10' 0" | 10' 0" | 10' 0" |
| Speed of Lift Loaded | 38 fpm | 38 fpm | 32 fpm | 30 fpm | 30 fpm | 24 fpm |
| Speed of Lift Empty | 48 fpm | 48 fpm | 48 fpm | 42 fpm | 42 fpm | 38 fpm |
| Speed of Travel | up to 16 mph | up to 14 mph | up to 15 mph | up to 15 mph | up to 15 mph | up to 16 mph |
| Fork Spacing Inside to Outside | 22" to 66" | 22" to 66" | 20" to 66" | 20" to 66" | 20" to 66" | 20" to 66" |
| Fork Length | 48" | 48" | 48" | 48" | 48" | 48" |
| Fork Section | 2 1/2" x 6" | 2 1/2" x 6" | 2 1/2" x 6" | 2 1/2" x 6" | 2 1/2" x 6" | 3" x 7" |
| Tilt Forward | 6° | 6° | 6° | 6° | 6° | 6° |
| Tilt Backward | 9° | 9° | 9° | 9° | 9° | 9° |
| Overall Width | 70 1/2" | 92 1/2" | 93" | 93" | 93" | 94 3/4" |
| Wheelbase | 106" | 106" | 106" | 106" | 115" | 115" |
| Overall Length Less Forks | 150" | 150" | 151" | 154" | 164" | 166" |
| Overall Length With Forks | 198" | 198" | 199" | 202" | 212" | 214" |
| Turning Radius | 21" | 10" | 10" | 10" | 10" | 10" |
| Tail Swing | 138" | 138" | 139" | 142" | 150" | 152" |
| Min. Width of Intersecting Aisle for 90° Turn | 117" | 117" | 118" | 121" | 129" | 131" |
| Underclearance Axle | 13" | 11 3/4" | 12 1/2" | 12 1/2" | 12 1/2" | 13" |
| Underclearance Mast | 12" | 11" | 10 1/2" | 10 1/2" | 10 1/2" | 11" |
| Tires | 9:00 x 15 | 7:50 x 15 | 8:25 x 15 | 8:25 x 15 | 8:25 x 15 | 9:00 x 15 |
| Total Weight | 15,700 lbs. | 16,000 lbs. | 17,650 lbs. | 19,500 lbs. | 19,600 lbs. | 20,900 lbs. |
| Weight on Drive Wheels | 9,100 lbs. | 9,500 lbs. | 10,200 lbs. | 10,200 lbs. | 10,200 lbs. | 10,500 lbs. |
| Weight on Steer Wheels | 6,600 lbs. | 6,500 lbs. | 9,450 lbs. | 9,300 lbs. | 9,400 lbs. | 10,400 lbs. |
| Ram Size | 6 1/2" | 6 1/2" | 6 1/2" | 6 1/2" | 6 1/2" | 7" |
| Axle C/L to Face of Carriage | 24" | 24" | 24" | 24" | 25" | 25" |
| Wheel Brakes † Vacuum Booster on Models S, G, & W | 16 1/2" x 4" | 16 1/2" x 4" | 16 1/2" x 4" | 16 1/2" x 4" | 16 1/2" x 4" | 16 1/2" x 4" |
| Engine | A | A | A | A | B | B |

A STANDARD—Continental Model F-244, 6 cyl.
 OPTIONAL—Ford V-8 Ind., Model J, OHV
 (At Extra Cost)—Hercules GO 298, 6 cyl.
 Hercules Diesel DD 298, 6 cyl.—85 H.P.

B STANDARD—Continental Model M-330, 6 cyl.
 OPTIONAL—Ford V-8 Ind., Model J, OHV
 Hercules GO 298, 6 cyl.
 (At Extra Cost)—Hercules Diesel DD 298, 6 cyl.—85 H.P.

C STANDARD—Ford V-8 Ind., Model J, OHV
 OPTIONAL—Hercules GO 298, 6 cyl.
 (At Extra Cost)—Hercules Diesel DD 298, 6 cyl.—85 H.P.

D STANDARD—Continental Model M-363, 6 cyl.
 OPTIONAL—Ford V-8 Ind., Model L, OHV
 Hercules GO 339, 6 cyl.
 (At Extra Cost)—Hercules Diesel DD 339, 6 cyl.—100 H.P.

E STANDARD—Continental Model T-6427, 6 cyl.
 (At Extra Cost)—Continental Diesel, 6 cyl.—147 H. P.

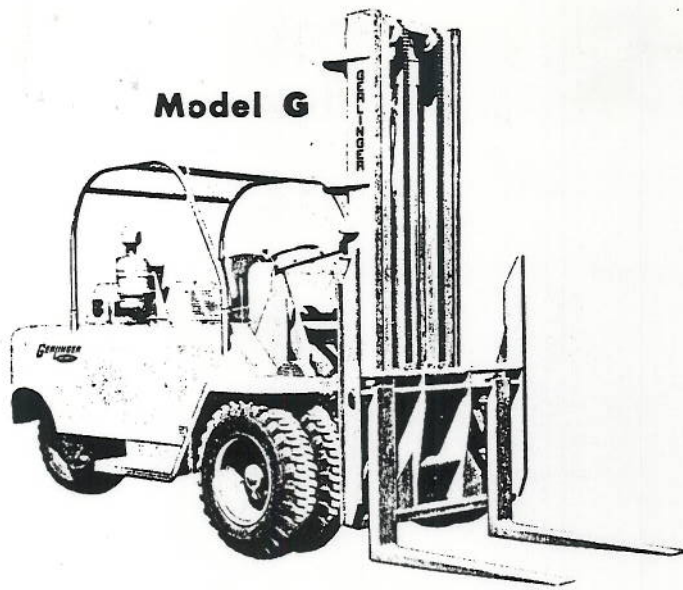

Model G

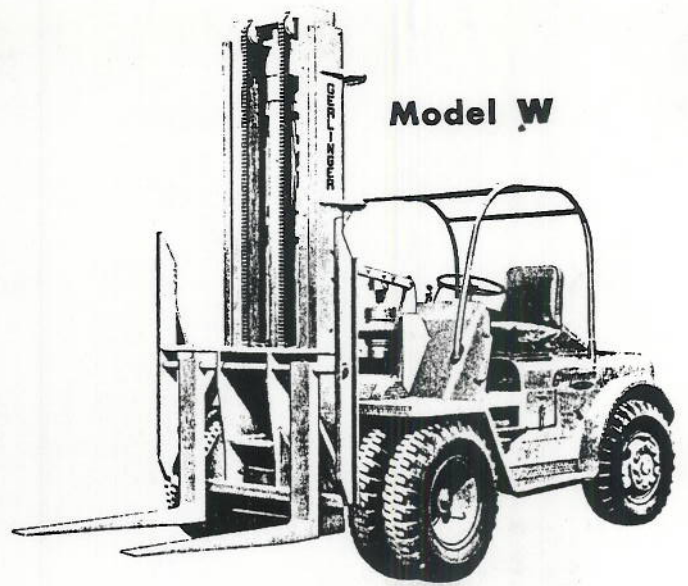

Model W

| MODEL | G-20 | G-22 | W-12 | W-15 | W-16 | W-18 | W-20 | W-22 |
|--|--------------------|--------------------|------------------|--------------------|--------------------|--------------------|--------------------|--------------------|
| Capacity | 20,000 lbs. | 22,000 lbs. | 12,000 lbs. | 15,000 lbs. | 16,000 lbs. | 18,000 lbs. | 20,000 lbs. | 22,000 lbs. |
| Load Center | 24" | 24" | 27" | 24" | 27" | 27" | 24" | 24" |
| Inch-Pound Rating with 135% Safety Factor | 1,100,000 in.-lbs. | 1,210,000 in.-lbs. | 648,000 in.-lbs. | 765,000 in.-lbs. | 920,000 in.-lbs. | 1,044,000 in.-lbs. | 1,100,000 in.-lbs. | 1,210,000 in.-lbs. |
| Inch-Pound Rating BALANCED | 1,485,000 in.-lbs. | 1,635,000 in.-lbs. | 876,000 in.-lbs. | 1,032,000 in.-lbs. | 1,240,000 in.-lbs. | 1,410,000 in.-lbs. | 1,485,000 in.-lbs. | 1,635,000 in.-lbs. |
| Height Mast Lowered | 9' 5 1/4" | 9' 5 1/4" | 9' 6 1/2" | 9' 6 1/2" | 9' 5 1/4" | 9' 5 1/4" | 9' 5 1/4" | 9' 5 1/4" |
| Height Mast Extended | 16' 1 1/4" | 16' 1 1/4" | 16' 3 1/4" | 16' 1 3/4" | 16' 1 3/4" | 16' 1 1/4" | 16' 1 1/4" | 16' 1 1/4" |
| Height of Lift | 10' 0" | 10' 0" | 10' 0" | 10' 0" | 10' 0" | 10' 0" | 10' 0" | 10' 0" |
| Speed of Lift Loaded | 40 fpm | 40 fpm | 60 fpm | 60 fpm | 60 fpm | 50 fpm | 42 fpm | 42 fpm |
| Speed of Lift Empty | 43 fpm | 43 fpm | 69 fpm | 69 fpm | 69 fpm | 60 fpm | 49 fpm | 49 fpm |
| Speed of Travel | up to 15 mph | up to 15 mph | up to 17 mph | up to 17 mph | up to 15 mph | up to 15 mph | up to 15 mph | up to 15 mph |
| Fork Spacing Inside to Outside | 20" to 66" | 20" to 66" | 20" to 66" | 20" to 66" | 20" to 66" | 20" to 66" | 20" to 66" | 20" to 66" |
| Fork Length | 48" | 48" | 48" | 48" | 48" | 48" | 48" | 48" |
| Fork Section | 3" x 7" | 3" x 7" | 2 1/2" x 6" | 2 1/2" x 6" | 2 1/2" x 6" | 3" x 7" | 3" x 7" | 3" x 7" |
| Tilt Forward | 7° | 7° | 7° | 7° | 7° | 7° | 7° | 7° |
| Tilt Backward | 8° | 8° | 8° | 8° | 8° | 8° | 8° | 8° |
| Overall Width | 94" | 94" | 93 1/4" | 93 1/4" | 94" | 94" | 94" | 94" |
| Wheelbase | 136" | 136" | 106" | 106" | 106" | 125" | 125" | 125" |
| Overall Length Less Forks | 201" | 203" | 172" | 172" | 176" | 195" | 195" | 195" |
| Overall Length With Forks | 249" | 251" | 220" | 220" | 224" | 243" | 243" | 243" |
| Turning Radius | 24" | 24" | 28" | 28" | 28" | 42" | 42" | 42" |
| Tail Swing | 175" | 177" | 169" | 169" | 169" | 185" | 185" | 185" |
| Min. Width of Intersecting Aisle for 90° Turn | 144" | 146" | 141" | 141" | 141" | 143" | 143" | 143" |
| Underclearance Axle | 16 1/2" | 16 1/2" | 15 3/4" | 15 1/4" | 16 1/2" | 16 1/2" | 16 1/2" | 16 1/2" |
| Underclearance Mast | 10 1/4" | 10 1/4" | 12" | 12" | 10 1/4" | 10 1/4" | 10 1/4" | 10 1/4" |
| Tires | 9-00 x 20 | 9-00 x 20 | 8-25 x 20 | 8-25 x 20 | 9-00 x 20 | 9-00 x 20 | 9-00 x 20 | 9-00 x 20 |
| Total Weight | 21,700 lbs. | 22,700 lbs. | 18,570 lbs. | 20,050 lbs. | 22,100 lbs. | 22,400 lbs. | 23,300 lbs. | 24,400 lbs. |
| Weight on Drive Wheels | 10,300 lbs. | 10,100 lbs. | 10,300 lbs. | 10,300 lbs. | 10,300 lbs. | 11,200 lbs. | 11,400 lbs. | 11,300 lbs. |
| Weight on Steer Wheels | 11,400 lbs. | 12,600 lbs. | 8,270 lbs. | 9,750 lbs. | 11,800 lbs. | 11,200 lbs. | 11,900 lbs. | 13,100 lbs. |
| Ram Size | 7 3/4" | 7 3/4" | 6 1/2" | 6 1/2" | 6 1/2" | 7" | 7 3/4" | 7 3/4" |
| Axle C/L to Face of Carriage | 31" | 31" | 27" | 27" | 31" | 31" | 31" | 31" |
| Wheel Brakes † Vacuum Booster on Models S, G, & W | 16 1/2" x 4" | 16 1/2" x 4" | 16 1/2" x 4" | 16 1/2" x 4" | 16 1/2" x 4" | 16 1/2" x 4" | 16 1/2" x 4" | 16 1/2" x 4" |
| Engine | C | C | A | A | B | B | B | B |

A STANDARD—Continental Model F-244, 6 cyl.
 OPTIONAL—Ford V-8 Ind., Model J, OHV
 (At Extra Cost)—Hercules GO 298, 6 cyl.
 Hercules Diesel DD 298, 6 cyl.—85 H.P.

B STANDARD—Continental Model M-330, 6 cyl.
 OPTIONAL—Ford V-8 Ind., Model J, OHV
 Hercules GO 298, 6 cyl.
 (At Extra Cost)—Hercules Diesel DD 298, 6 cyl.—85 H.P.

C STANDARD—Ford V-8 Ind., Model J, OHV
 OPTIONAL—Hercules GO 298, 6 cyl.
 (At Extra Cost)—Hercules Diesel DD 298, 6 cyl.—85 H.P.

D STANDARD—Continental Model M-363, 6 cyl.
 OPTIONAL—Ford V-8 Ind., Model L, OHV
 Hercules GO 339, 6 cyl.
 (At Extra Cost)—Hercules Diesel DD 339, 6 cyl.—100 H.P.

E STANDARD—Continental Model T-6427, 6 cyl.
 (At Extra Cost)—Continental Diesel, 6 cyl.—147 H. P.

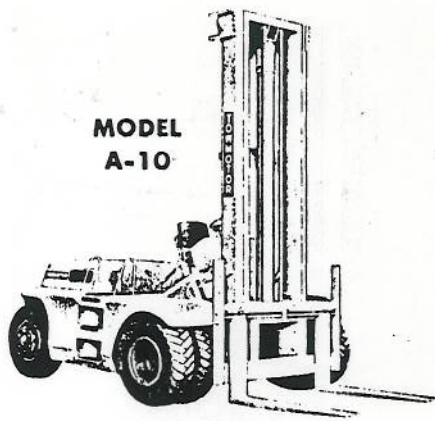

**MODEL
A-10**

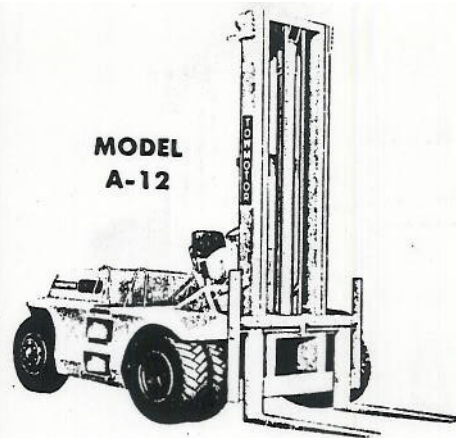

**MODEL
A-12**

| MODEL | A-10 | A-12 | A-15 | A-16 |
|---|---|--|--|---|
| Capacity | 10,000 lbs. | 12,000 lbs. | 15,000 lbs. | 16,500 lbs. |
| | 470,000 in.-lbs. | 564,000 in.-lbs. | 754,000 in.-lbs. | 829,000 in.-lbs. |
| Load Center | 24" | 24" | 24" | 24" |
| Height of Mast Lowered | 8' 2 1/4" | 8' 3" | 9' 2" | 9' 2" |
| Height of Mast Extended | 13' 2 1/4" | 13' 3" | 14' 1 1/4" | 14' 1 1/4" |
| Height of Carriage Raised | 14' 0" | 14' 0" | 15' 6" | 15' 6" |
| Height of Lift | 10' 0" | 10' 0" | 10' 0" | 10' 0" |
| Speed of Lift Loaded | 65 fpm | 65 fpm | 75 fpm | 75 fpm |
| Speed of Lift Empty | 80 fpm | 80 fpm | 105 fpm | 105 fpm |
| Speed of Travel | 20 mph | 20 mph | 23 mph | 23 mph |
| Fork Spacing Inside to Outside | 2" to 66" | 2" to 66" | 2" to 66" | 2" to 66" |
| Fork Length | 48" | 48" | 48" | 48" |
| Fork Section | 2" x 7" | 2" x 7" | 2 1/2" x 6" | 2 1/2" x 6" |
| Tilt Forward | 6° | 6° | 6° | 6° |
| Tilt Backward | 12° | 12° | 12° | 12° |
| Overall Width | 90" | 90" | 96" | 96" |
| Wheelbase | 86" | 86" | 106" | 106" |
| Overall Length Less Forks | 143" | 143" | 168" | 168" |
| Overall Length With Forks | 191" | 191" | 216" | 216" |
| Inside Turning Radius | 9" | 9" | 13" | 13" |
| Outside Turning Radius | 134" | 134" | 158" | 158" |
| Min. Width of Intersecting Aisle for 90° Turn | 125" | 125" | 145" | 145" |
| Tires | 7:50 x 15 | 8:25 x 15 | 9:00 x 20 | 9:00 x 20 |
| Total Weight Empty | 15,300 lbs. | 16,730 lbs. | 21,650 lbs. | 22,550 lbs. |
| Empty Weight on Drive Wheels | 8,200 lbs. | 8,200 lbs. | 12,400 lbs. | 12,350 lbs. |
| Empty Weight on Steer Wheels | 7,110 lbs. | 8,530 lbs. | 9,250 lbs. | 10,200 lbs. |
| CL of Axle to Face of Fork | 23" | 23" | 26 1/4" | 26 1/4" |
| Wheel Brakes | 12" x 2 1/2" | 12" x 2 1/2" | 16" x 6" | 16" x 6" |
| ENGINE | Standard Diesel Std. Trans. Auto. Trans. | Continental F-244 Hercules DD226H | Continental F-244 Hercules DD226H | Continental M-330 Hercules D298H D339H |

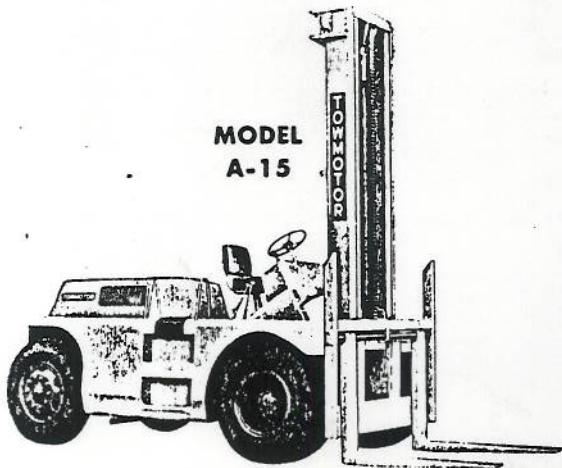

**MODEL
A-15**

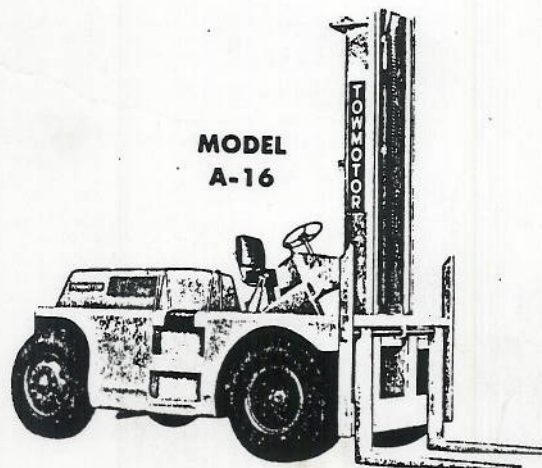

**MODEL
A-16**

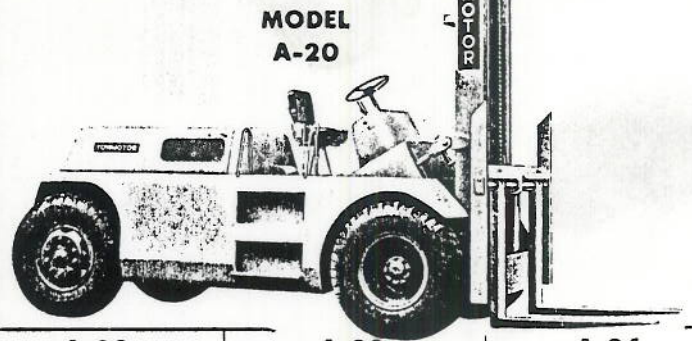
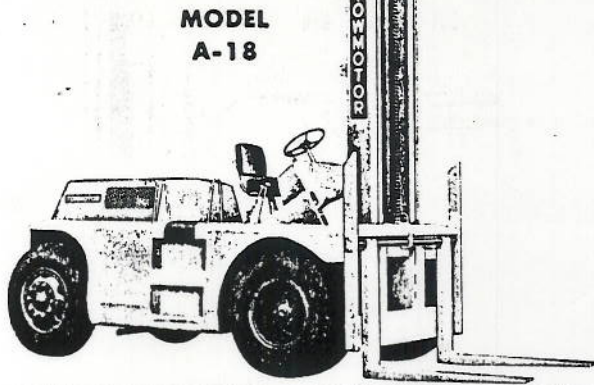

| MODEL | A-18 | A-20 | A-22 | A-24 |
|---|-------------------|--------------------|--------------------|--------------------|
| Capacity | 18,000 lbs. | 20,000 lbs. | 22,000 lbs. | 24,000 lbs. |
| | 905,000 in.-lbs. | 1,050,000 in.-lbs. | 1,155,000 in.-lbs. | 1,260,000 in.-lbs. |
| Load Center | 24" | 24" | 24" | 24" |
| Height of Mast Lowered | 9' 2" | 9' 5 3/4" | 9' 5 3/4" | 9' 5 3/4" |
| Height of Mast Extended | 14' 1 3/4" | 14' 5 1/2" | 14' 5 1/2" | 14' 5 1/2" |
| Height of Carriage Raised | 15' 6" | 15' 5 1/2" | 15' 5 1/2" | 15' 5 1/2" |
| Height of Lift | 10' 0" | 10' 0" | 10' 0" | 10' 0" |
| Speed of Lift Loaded | 75 fpm | 50 fpm | 50 fpm | 50 fpm |
| Speed of Lift Empty | 105 fpm | 75 fpm | 75 fpm | 75 fpm |
| Speed of Travel | 23 mph | 23 mph | 23 mph | 23 mph |
| Fork Spacing Inside to Outside | 2" to 66" | 2" to 66" | 2" to 66" | 2" to 66" |
| Fork Length | 48" | 48" | 48" | 48" |
| Fork Section | 2 1/2" x 7" | 3" x 7" | 3" x 7" | 3" x 7" |
| Tilt Forward | 6° | 6° | 6° | 6° |
| Tilt Backward | 12° | 12° | 12° | 12° |
| Overall Width | 96" | 96" | 96" | 96" |
| Wheelbase | 105" | 120" | 120" | 120" |
| Overall Length Less Forks | 165" | 184" | 187" | 187" |
| Overall Length With Forks | 216" | 232" | 235" | 235" |
| Inside Turning Radius | 13" | 16" | 16" | 16" |
| Outside Turning Radius | 158" | 171" | 173" | 173" |
| Min. Width of Intersecting Aisle for 90° Turn | 145" | 155" | 157" | 157" |
| Tires | 9:00 x 20 | 10:00 x 20 | 10:00 x 20 | 10:00 x 20 |
| Total Weight Empty | 23,500 lbs. | 24,650 lbs. | 25,630 lbs. | 26,680 lbs. |
| Empty Weight on Drive Wheels | 12,400 lbs. | 13,150 lbs. | 13,000 lbs. | 12,900 lbs. |
| Empty Weight on Steer Wheels | 11,100 lbs. | 11,500 lbs. | 12,630 lbs. | 13,780 lbs. |
| CL of Axle to Face of Fork | 26 1/4" | 28 1/2" | 28 1/2" | 28 1/2" |
| Wheel Brakes | 16" x 6" | 16" x 6" | 16" x 6" | 16" x 6" |
| Standard ENGINE | Continental M-330 | Continental M-330 | Continental M-330 | Continental M-330 |
| Diesel | Hercules | Hercules | Hercules | Hercules |
| Sid. Trans. | D298H | D298H | D298H | D298H |
| Auto. Trans. | D339H | D339H | D339H | D339H |

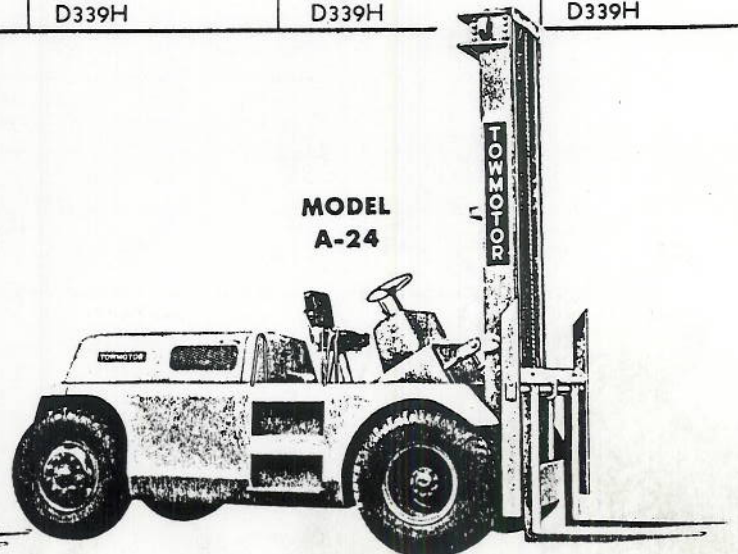
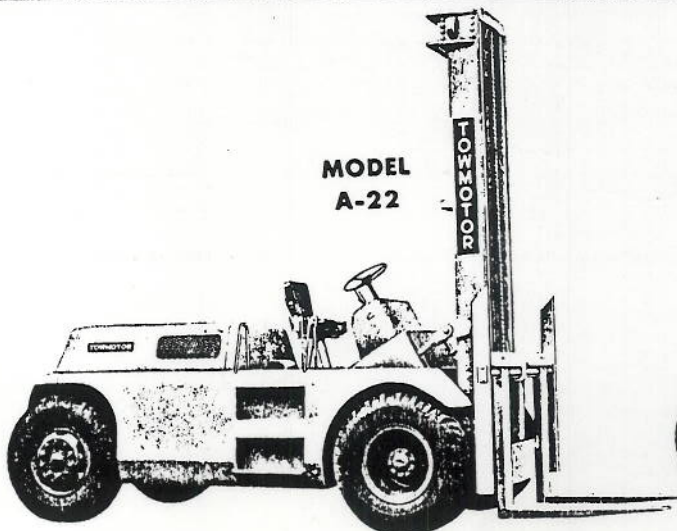

Model H

Model M

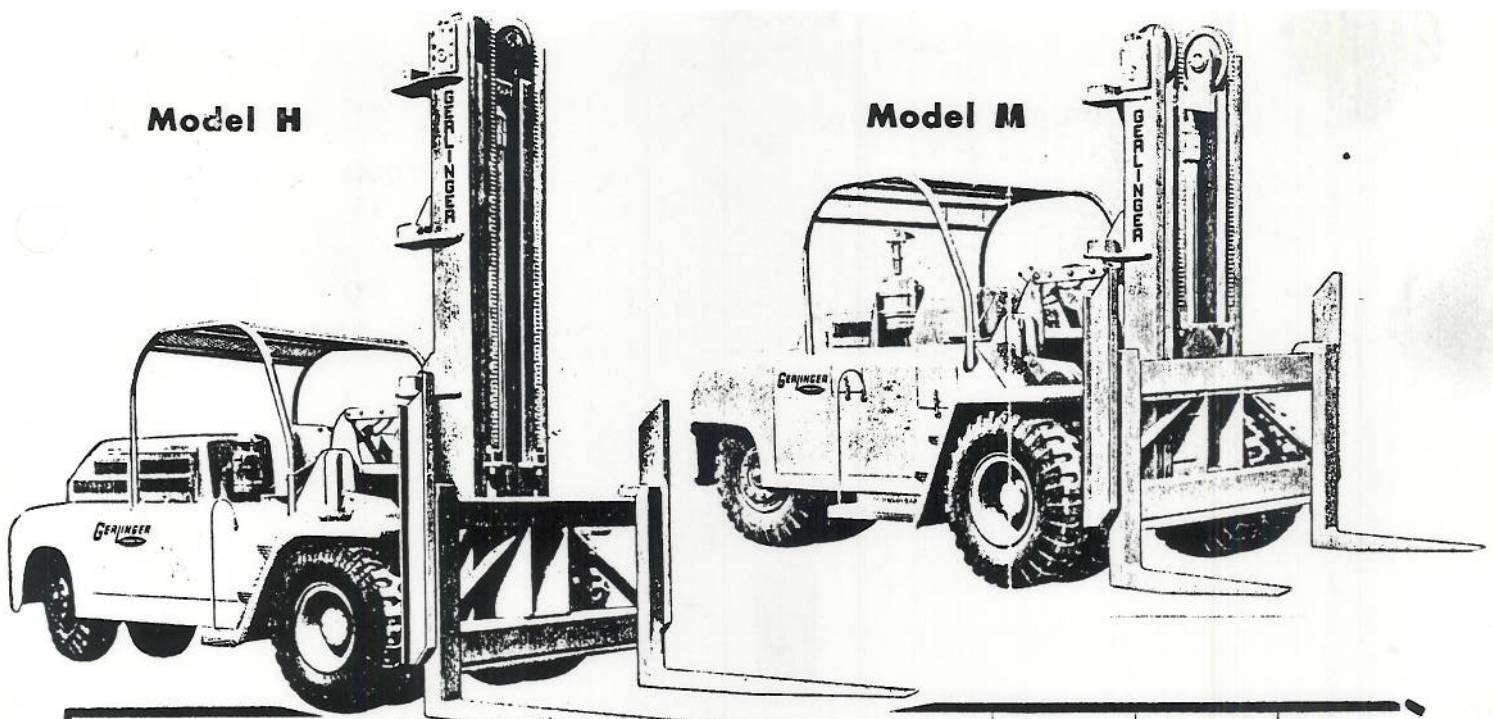

| MODEL | H-32 | H-36 | H-40 | M-24 | M-26 | M-28 | M-30 |
|--|-----------------------------------|-----------------------------------|-----------------------------------|-----------------------------------|-----------------------------------|-----------------------------------|-----------------------------------|
| Capacity | 32,000 lbs. | 36,000 lbs. | 40,000 lbs. | 24,000 lbs. | 26,000 lbs. | 28,000 lbs. | 30,000 lbs. |
| Load Center | 36" | 36" | 36" | 36" | 36" | 36" | 36" |
| Inch-Pound Rating with 135% Safety Factor | 2,400,000 in-lbs. | 2,700,000 in-lbs. | 3,000,000 in-lbs. | 1,752,000 in-lbs. | 1,900,000 in-lbs. | 2,045,000 in-lbs. | 2,190,000 in-lbs. |
| Inch-Pound Rating BALANCED | 3,240,000 in-lbs. | 3,645,000 in-lbs. | 4,050,000 in-lbs. | 2,370,000 in-lbs. | 2,570,000 in-lbs. | 2,760,000 in-lbs. | 2,960,000 in-lbs. |
| Height Mast Lowered | 12' 2" | 12' 2" | 12' 2" | 12' 1/2" | 12' 1" | 12' 1 3/4" | 12' 2 1/2" |
| Height Mast Extended | 17' | 17' | 17' | 16' 10 1/2" | 16' 11" | 16' 11 3/4" | 17 1/4" |
| Height of Lift | 10' 0" | 10' 0" | 10' 0" | 10' 0" | 10' 0" | 10' 0" | 10' 0" |
| Speed of Lift Loaded | 35 fpm | 35 fpm | 35 fpm | 34 fpm | 34 fpm | 34 fpm | 34 fpm |
| Speed of Lift Empty | 38 fpm | 38 fpm | 38 fpm | 38 fpm | 38 fpm | 38 fpm | 38 fpm |
| Speed of Travel | up to 16 mph | up to 16 mph | up to 16 mph | up to 16 mph | up to 16 mph | up to 17 mph | up to 15 mph |
| Fork Spacing Inside to Outside | 0" to 108" | 0" to 108" | 0" to 108" | 0" to 100" | 0" to 100" | 0" to 100" | 0" to 100" |
| Fork Length | 72" | 72" | 72" | 48" | 48" | 48" | 48" |
| Fork Section | 4" x 9" | 4" x 9" | 4" x 9" | 4" x 7" | 4" x 7" | 4" x 7" | 4" x 7" |
| Tilt Forward | 6° | 6° | 6° | 6° | 6° | 6° | 6° |
| Tilt Backward | 10° | 10° | 10° | 10° | 10° | 10° | 10° |
| Overall Width | 113 1/2" | 113 1/2" | 113 1/2" | 106" | 106 3/4" | 107 1/2" | 112 1/2" |
| Wheelbase | 172" | 172" | 172" | 158" | 158" | 158" | 158" |
| Overall Length Less Forks | 252" | 255" | 257" | 235" | 235" | 235" | 235" |
| Overall Length With Forks | 324" | 327" | 329" | 283" | 283" | 283" | 283" |
| Turning Radius | 48" | 48" | 48" | 42" | 42" | 42" | 42" |
| Tail Swing | 257" | 260" | 262" | 236" | 236" | 236" | 236" |
| Min. Width of Intersecting Aisle for 90° Turn | 209" | 212" | 214" | 188" | 188" | 188" | 188" |
| Underclearance Axle | 20 3/4" | 20 3/4" | 20 3/4" | 16 1/4" | 16 3/4" | 17 1/2" | 18" |
| Underclearance Mast | 12 1/2" | 12 1/2" | 12 1/2" | 12" | 12 1/2" | 13 1/4" | 13 3/4" |
| Tires | 14:00 x 24 20 ply | 14:00 x 24 20 ply | 14:00 x 24 20 ply | 10:00 x 20 12 ply | 11:00 x 20 14 ply | 12:00 x 20 16 ply | 13:00 x 20 20 ply |
| Total Weight | 45,734 lbs. | 47,630 lbs. | 49,600 lbs. | 38,850 lbs. | 39,900 lbs. | 40,950 lbs. | 42,000 lbs. |
| Weight on Drive Wheels | 26,884 lbs. | 26,430 lbs. | 26,000 lbs. | 23,250 lbs. | 23,000 lbs. | 22,750 lbs. | 22,500 lbs. |
| Weight on Steer Wheels | 18,850 lbs. | 21,200 lbs. | 23,600 lbs. | 15,600 lbs. | 16,900 lbs. | 18,200 lbs. | 19,500 lbs. |
| Ram Size | 9 1/2" | 9 1/2" | 9 1/2" | 8 1/2" | 8 1/2" | 8 1/2" | 8 1/2" |
| Axle C/L to Face of Carriage | 39" | 39" | 39" | 37" | 37" | 37" | 37" |
| Wheel Brakes 1 Vacuum Booster on Models S, G, & W | 16 1/2" x 7" Full air actuated | 16 1/2" x 7" Full air actuated | 16 1/2" x 7" Full air actuated | 16 1/2" x 7" Full air actuated | 16 1/2" x 7" Full air actuated | 16 1/2" x 7" Full air actuated | 16 1/2" x 7" Full air actuated |
| Engine | E | E | E | D | D | D | D |

A STANDARD—Continental Model T-244, 6 cyl.
 OPTIONAL—Ford V-8 Ind., Model J, OHV
 (At Extra Cost)—Hercules GO 298, 6 cyl.
 Hercules Diesel DD 298, 6 cyl.—85 H.P.

B STANDARD—Continental Model M-110, 6 cyl.
 OPTIONAL—Ford V-8 Ind., Model J, OHV
 Hercules GO 298, 6 cyl.
 (At Extra Cost)—Hercules Diesel DD 298, 6 cyl.—85 H.P.

C STANDARD—Ford V-8 Ind., Model J, OHV
 OPTIONAL—Hercules GO 298, 6 cyl.
 (At Extra Cost)—Hercules Diesel DD 298, 6 cyl.—85 H.P.

D STANDARD—Continental Model M-363, 6 cyl.
 OPTIONAL—Ford V-8 Ind., Model L, OHV
 Hercules GO 339, 6 cyl.
 (At Extra Cost)—Hercules Diesel DD 339, 6 cyl.—100 H.P.

E STANDARD—Continental Model T-6427, 6 cyl.
 (At Extra Cost)—Continental Diesel, 6 cyl.—147 H. P.

MODEL U-6
6000 lbs. Capacity

MODEL U-8
8000 lbs. Capacity

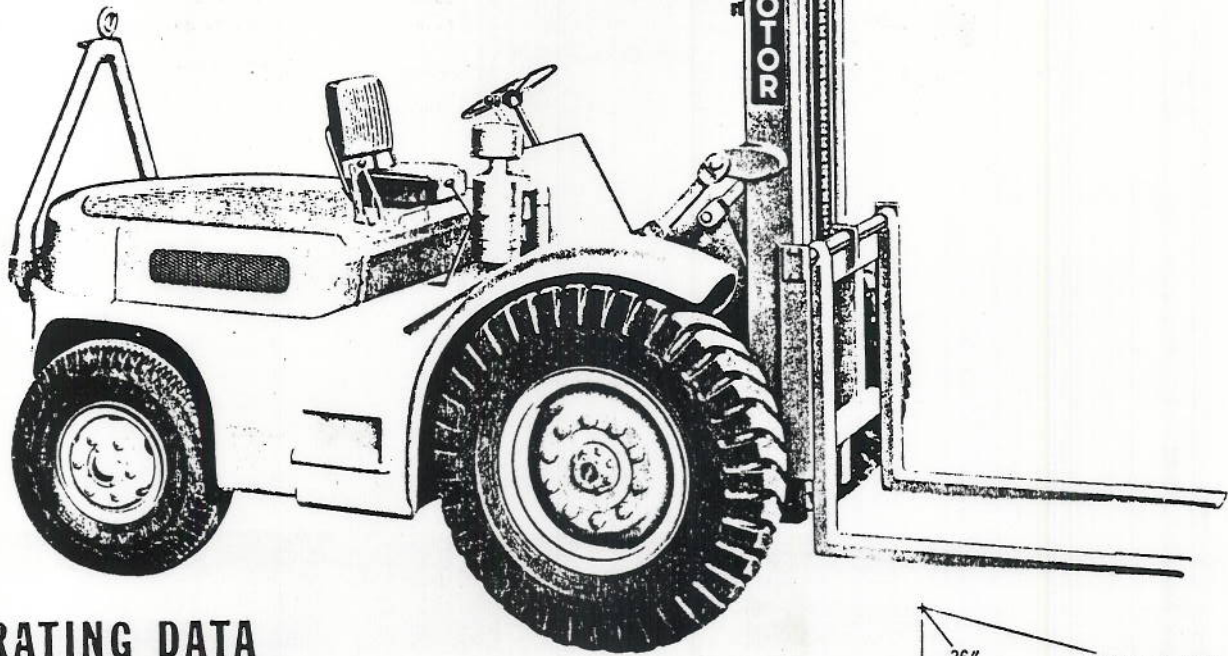

OPERATING DATA

| | U-6 | U-8 |
|---|-----------------------------------|-----------------------------------|
| Capacity..... | 6,000 lbs. 300,000 in.-lbs. | 8,000 lbs. 400,000 in.-lbs. |
| Load Center..... | 24" | 24" |
| Height of Mast Lowered..... | 9'6½" | 9'6½" |
| Height of Mast Extended..... | 15'6½" | 15'6½" |
| Height of Carriage Raised..... | 15'6½" | 15'6½" |
| Height of Lift..... | 12'0" | 12'0" |
| Speed of Lift Loaded..... | 65 fpm | 60 fpm |
| Speed of Lift Empty..... | 75 fpm | 75 fpm |
| Speed of Travel..... | 35 mph | 35 mph |
| Fork Spacing Inside to Outside..... | 2" to 48" | 2" to 48" |
| Fork Length..... | 48" | 48" |
| Fork Section..... | 2" x 5" | 2" x 5" |
| Tilt Forward..... | 10° | 10° |
| Tilt Backward..... | 12° | 12° |
| Overall Width..... | 81¼" | 81¼" |
| Wheelbase..... | 80" | 80" |
| Overall Length Less Forks..... | 140" | 140" |
| Overall Length With Forks..... | 188" | 188" |
| Inside Turning Radius..... | 36" | 36" |
| Outside Turning Radius..... | 144" | 144" |
| Min. Width of Intersecting Aisle for 90° turn..... | 120" | 120" |
| Tires-Drive (Front)..... | 12:00 x 24 6 ply | 12:00 x 24 8 ply |
| Steer (Rear)..... | 8:25 x 15 12 ply | 9:00 x 15 12 ply |
| Total Weight Empty..... | 11,790 lbs. | 12,900 lbs. |
| Empty Weight on Drive Wheels..... | 6,920 lbs. | 6,400 lbs. |
| Empty Weight on Steer Wheels..... | 4,870 lbs. | 6,500 lbs. |
| CL of Axle to Face of Fork..... | 26" | 26" |
| Wheel Brakes..... | 12" x 2½" | 12" x 2½" |
| Engine, Standard..... | Continental F-244 | F-244 |

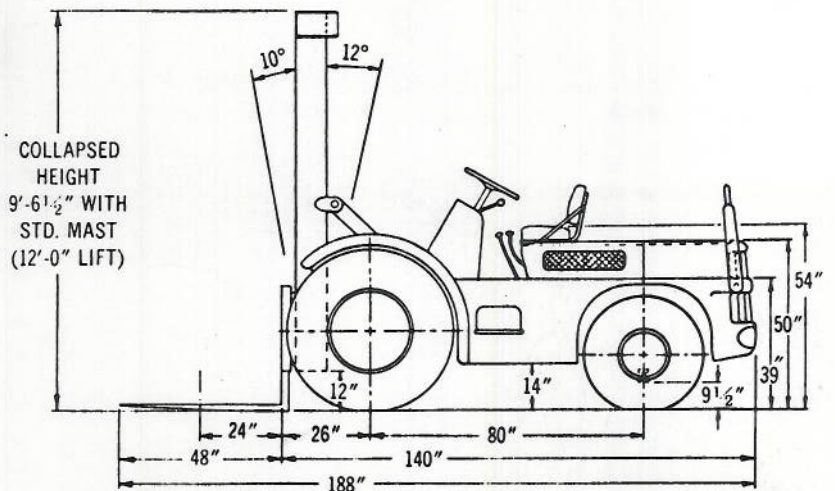
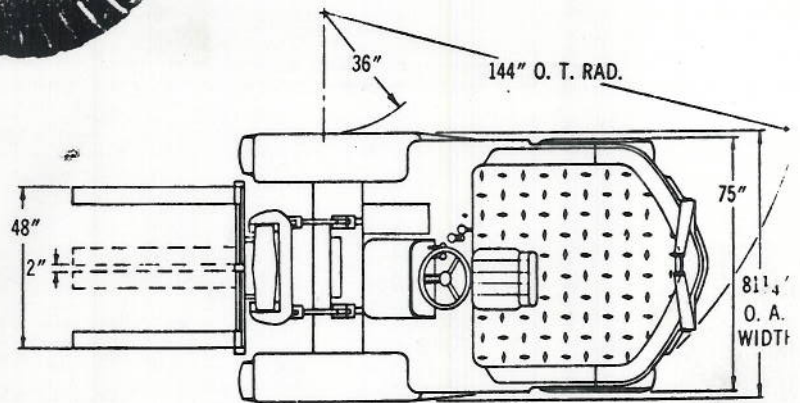

**MODEL
590SG4024
NARROW-AISLE
STACK**

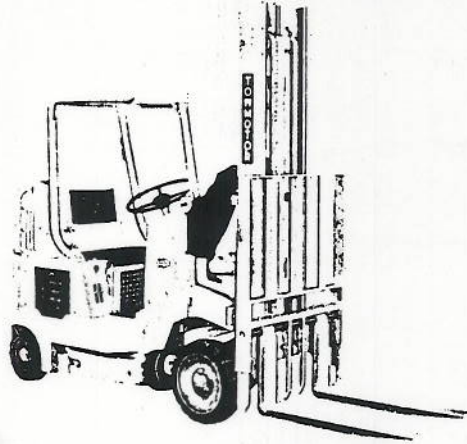

Capacity, Lbs.....4000
 Load Center......24"
 Inch-Pound Rating.....149,000
 Centerline of Drive Axle to Fork Face......13 1/4"
 Maximum Lift Height with Rated Load......144"
 Maximum Fork Height......146 1/4"
 Mast Lowered Height......90"
 Mast Extended Height { Less Load Backrest......164 1/4"
 With Load Backrest......194"
 Free Lift......17 3/4"
 Truck Weight, Lbs......7200

Tilt: Conventional { Forward......3°
 Backward......5°
 Stacking { Forward.....Up to 3°
 Backward.....Up to 5°

Speed of Lift, Loaded......75 fpm
 Speed of Travel.....Up to 8.0 mph
 Carriage Width......36"
 Carriage Height { Less Load Backrest......20 1/4"
 With Load Backrest......50"
 Forks, Standard Section and Length......1 3/4" x 4" x 36"
 Lateral Adjustment, In to In......6 1/2"
 Lateral Adjustment, Out to Out......33 3/8"
 Turning Radius { Outside......82 1/4"
 Inside......5 1/8"
 Minimum Intersecting Aisle......67 3/4"
 Minimum Aisle for Right Angle Stacking:
 Conventional......95 1/2" Plus Load Length
 Narrow Aisle—36" x 36" Load......72"
 Narrow Aisle—48" x 48" Load......84 1/2"
 Overall Width......36 1/2"
 Wheelbase......59"
 Overall Length, Less Forks and Towing Eye......91 1/8"
 Driver's Overhead Guard Height......71"
 Effective Seat Height......32"
 Tread, Steer—Drive......30 1/2"-30 1/2"
 Tire Size:
 Steer......13 1/2" x 5 1/2" x 8"
 Drive......18" x 6" x 12 1/8"
 Outrigger......9" x 5" x 5" Solid
 Underclearance, Center of Truck......4 3/4"
 Engine, Continental Model.....Y-112
 Optional Power Types Available.....LP-Gas

**TOWMOTOR
INDUSTRIAL
TRACTORS**

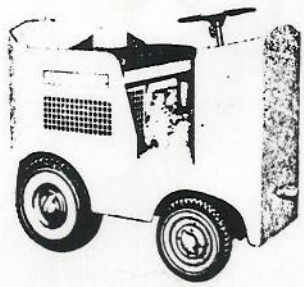

| MODEL | K5-30 | K5-33 | K5-36 | K5-40 |
|--|-------|-------|-------|-------|
| Drawbar Capacity, Lbs.... | 3000 | 3300 | 3600 | 4000 |
| Capacity Trailing Load on Dry Level Concrete—Tons. | 73 | 80 | 88 | 98 |
| Tractor Weight, Lbs..... | 3500 | 3950 | 4260 | 4550 |

Speed of Travel.....Up to 10.0 mph
 Turning Radius { Outside......64"
 Inside......9 1/2"
 Minimum Intersecting Aisle......53"
 Overall Height......54 5/8"
 Overall Width......40 3/4"
 Overall Length, Less Towing Eyes..67"
 Wheelbase......36 1/2"
 Effective Seat Height......43"
 Tread, Steer—Drive......33 3/8"-30 3/16"
 Tire Size, Steer......17" x 4 1/2" x 12 1/8"
 Tire Size, Drive......22" x 8" x 16"
 Underclearance, Center of Truck..11"
 Engine, Continental Model.....F-163
 For more detailed information, ask for Literature Sheet Number....F-13

**TOWMOTOR
ELECTRIC
PALLET TRUCK**

Model "W"
Capacity 4,000 lbs.

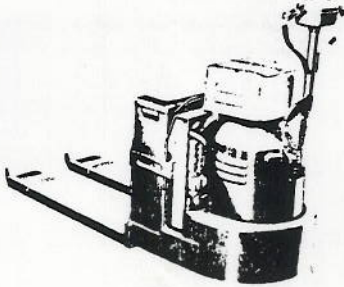

Speed of Travel.....3.3 mph Empty, 2.2 mph Loaded
 Lift Height......4"
 Lifting Time.....5 Seconds (4000 lbs. Load)
 Lowering Time....4 Seconds (Controlled by Solenoid Flow Valve)
 Forks, Standard Length...30", 36", 42", 48", 54", 60", 66", 72"
 Forks, Standard Width......9"
 Forks, Outside to Outside Width......27"
 Forks, Height in Lowered Position......3 1/4"
 Length, Overall, Handle Vertical.....30" plus fork length
 Length, Overall, Handle Horizontal.....51" plus fork length
 Width, Overall......27" with Lead-Acid Type Battery
 29" with Edison Type Battery
 Height, Overall, Handle Vertical......46"
 Underclearance { Forks Lowered......1"
 Forks Raised......3 1/4" with 48" Forks
 Wheelbase { Forks Lowered......12 1/2" plus fork length
 Forks Raised......9" plus fork length
 Steering Arc......190 Degrees
 Tires, Drive, Press-on......9 3/8" x 5" x 5" Non-Skid
 Tires, Trailer, Special:
 30" Forks......3 1/4" O.D. x 6" width Single Steel
 36" through 72" Forks......3 1/4" O.D. x 3" width Dual Rubber
 Weight without Battery......920 lbs. (with 48" Forks)
 Weight with Lead-Acid Battery......1280 lbs.
 Weight with Edison Battery......1240 lb